

Please write clearly in block capitals.

Centre number

Candidate number

Surname _____

Forename(s) _____

Candidate signature _____

I declare this is my own work.

INTERNATIONAL AS PHYSICS

Unit 1 Mechanics, materials and atoms

Tuesday 4 January 2022

07:00 GMT

Time allowed: 2 hours

Materials

For this paper you must have:

- a Data and Formulae Booklet as a loose insert
- a ruler with millimetre measurements
- a scientific calculator, which you are expected to use where appropriate
- a protractor.

Instructions

- Use black ink or black ball-point pen.
- Fill in the boxes at the top of this page.
- Answer **all** questions.
- You must answer the questions in the spaces provided. Do not write outside the box around each page or on blank pages.
- All working must be shown.
- If you need extra space for your answer(s), use the lined pages at the end of this book. Write the question number against your answer(s).
- Do all rough work in this book. Cross through any work you do not want to be marked.

Information

- The marks for questions are shown in brackets.
- The maximum mark for this paper is 80.

For Examiner's Use	
Question	Mark
1	
2	
3	
4	
5	
6	
7	
8	
9	
10–23	
TOTAL	

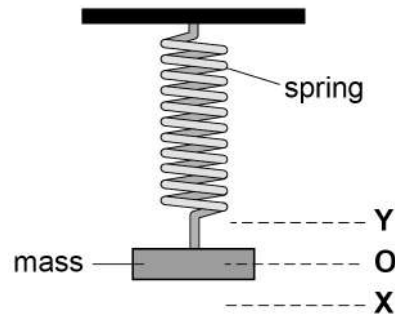

Section AAnswer **all** questions in this section.**0 1****Figure 1** shows a mass hanging in its equilibrium position **O** on a light, vertical spring.**Figure 1**

The mass is pulled down to position **X** and then released. The mass reaches a maximum height at position **Y**.

Describe the energy transfers in the system as the mass moves from **X** to **Y**.

[4 marks]

4



0 2 . 1

State the condition that is necessary for momentum to be conserved during a collision.

[1 mark]

0 2 . 2

Figure 2 shows two gliders **X** and **Y** moving horizontally on a frictionless track. Initially:

- **X** is moving to the right at a speed of 0.90 m s^{-1}
- **Y** is moving to the left at a speed of 0.80 m s^{-1} .

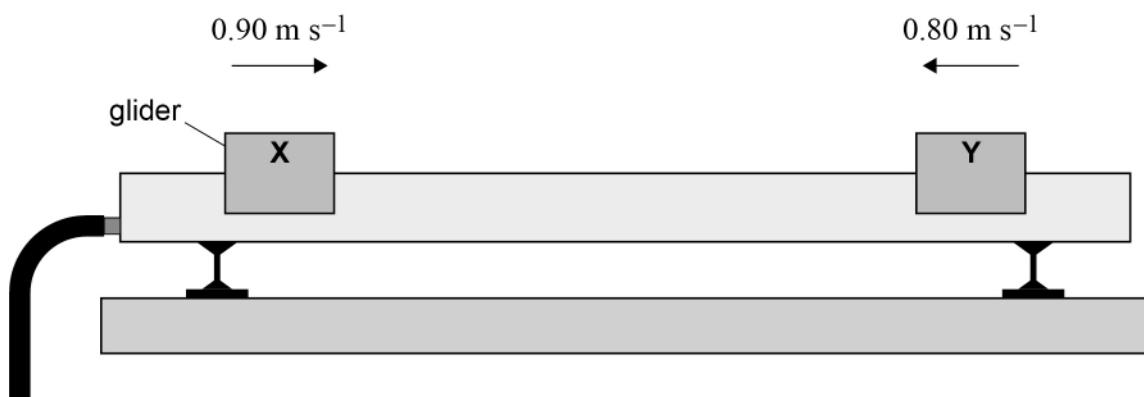
Figure 2

The gliders collide.

After the collision:

- **X** moves to the left at a speed of 0.30 m s^{-1}
- **Y** moves to the right at a speed of 0.15 m s^{-1} .

The mass of **X** is 0.050 kg .

Calculate the mass of **Y**.

[3 marks]

mass of **Y** = _____ kg

4

Turn over ►



0 3

Figure 3 is a velocity–time graph for a moving object. The displacement of the object is zero at time $t = 0$

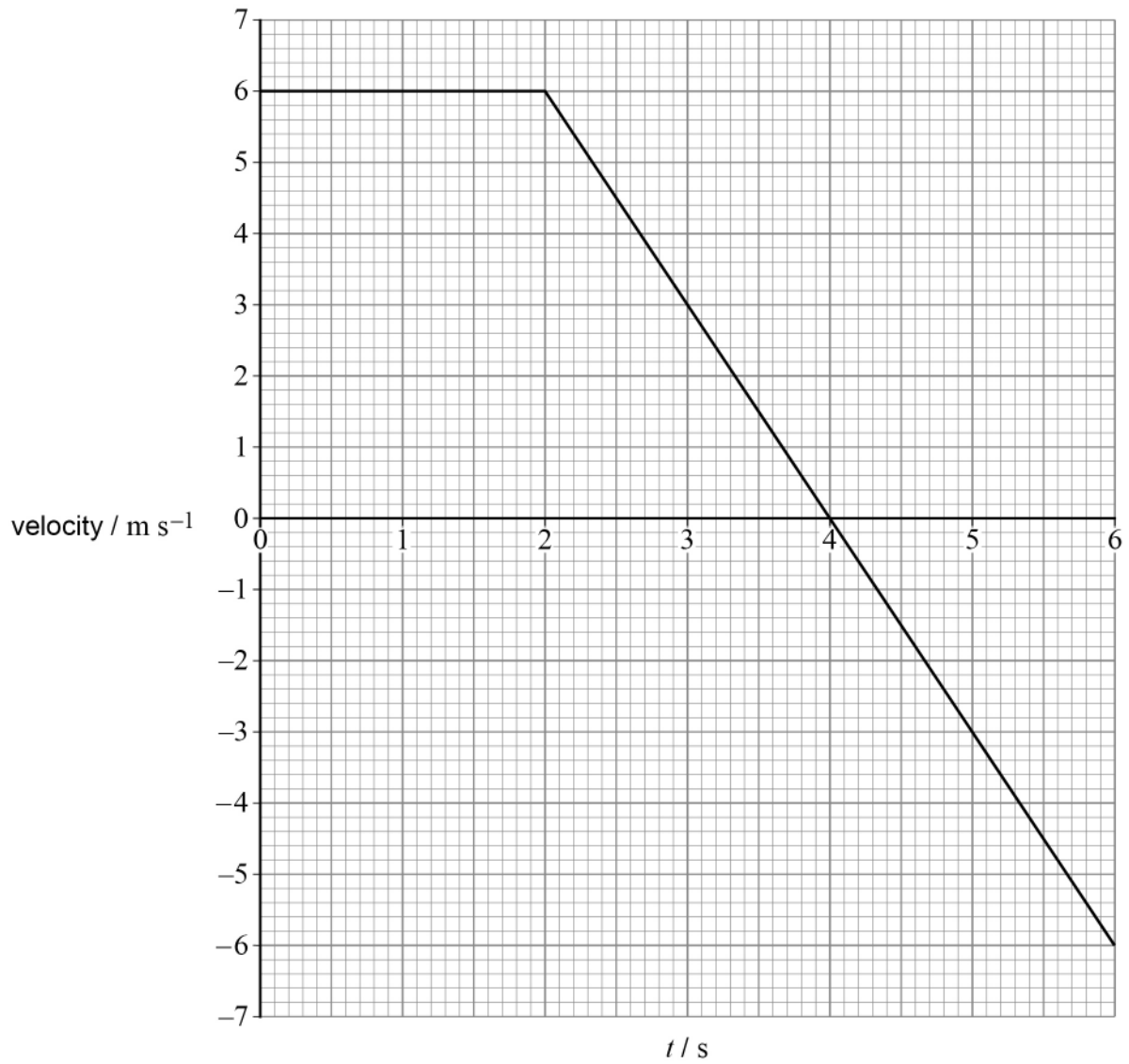
Figure 3

Plot, on **Figure 4**, the displacement–time graph for the object between 0 and 6 s.

[4 marks]

Figure 4

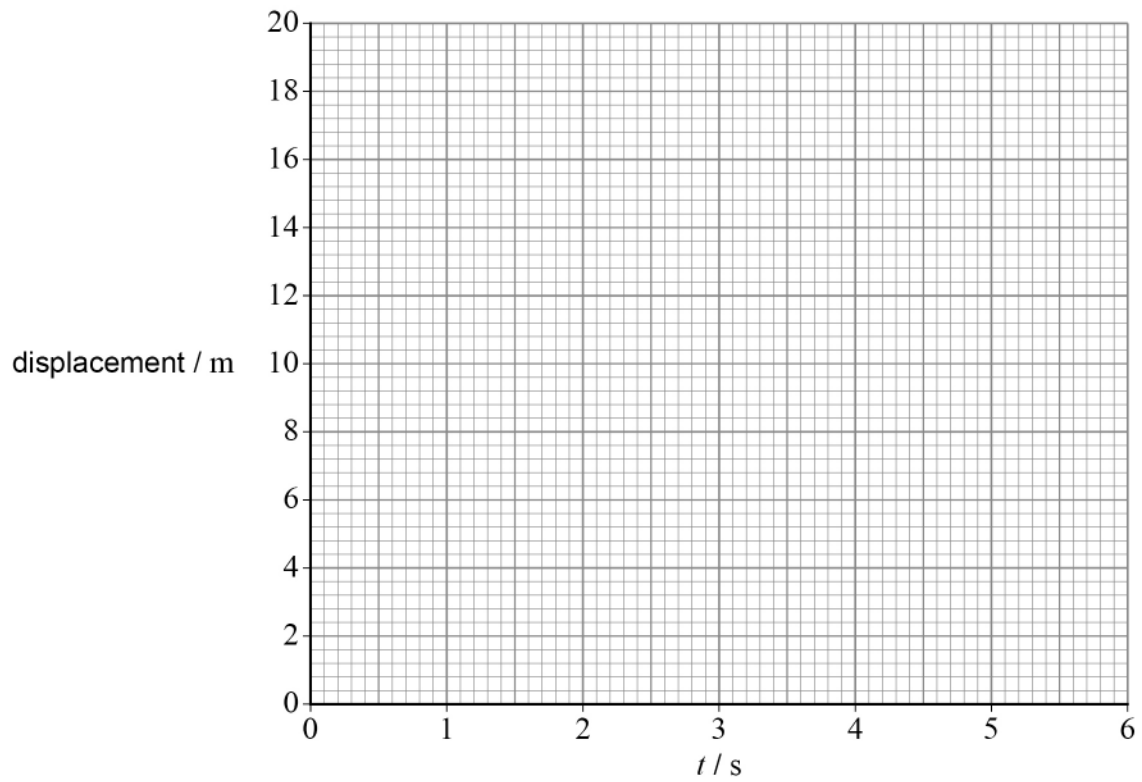

Do not write
outside the
box

4

Turn over for the next question

Turn over ►



0 4 . 1 State the products of the decay of a free neutron.

[2 marks]

Two different experimental methods **A** and **B** are used to determine the average time t_n for the decay of a free neutron. **Table 1** shows the result of each method.

Table 1

Method	t_n / s
A	887.7 ± 2.2
B	878.5 ± 0.8

0 4 . 2 Compare the precision of the measurement of t_n determined by methods **A** and **B**.

[1 mark]

0 4 . 3 State what is meant by a reproducible measurement.

[1 mark]



0 4 . 4

Discuss whether methods **A** and **B** have provided a reproducible measurement of t_n .**[2 marks]**

6**Turn over for the next question****Turn over ►**

0 5

Gold ions collide in a particle accelerator. Each ion is made by removing 77 electrons from an atom of gold (${}_{79}^{197}\text{Au}$) in two stages.

0 5 . 1

In the first stage, ions of ${}_{79}^{197}\text{Au}^{32+}$ are made.

Calculate the number of electrons in an ${}_{79}^{197}\text{Au}^{32+}$ ion.

[1 mark]

number of electrons = _____

0 5 . 2

In the second stage, more electrons are removed to produce ions of ${}_{79}^{197}\text{Au}^{77+}$.

Calculate the specific charge of an ${}_{79}^{197}\text{Au}^{77+}$ ion.

[3 marks]

specific charge = _____ C kg^{-1}



Collisions between the gold ions produce nuclei of antimatter helium-4 (${}^4_2\text{He}$).

0 5 . 3 State the constituents of one nucleus of antimatter helium-4

[2 marks]

0 5 . 4 Collisions between the gold ions lead to two annihilations:

- a nucleus of antimatter helium with a nucleus of helium
- an antiproton with a proton.

Both annihilations produce radiation.

The kinetic energy of the annihilating particles is negligible.

Compare the radiation produced as a result of the two different annihilations.

[3 marks]



0 6

Figure 5 shows a uniform rod **AB** of length 30 cm and mass 6.0 g.
The rod is supported at each end.

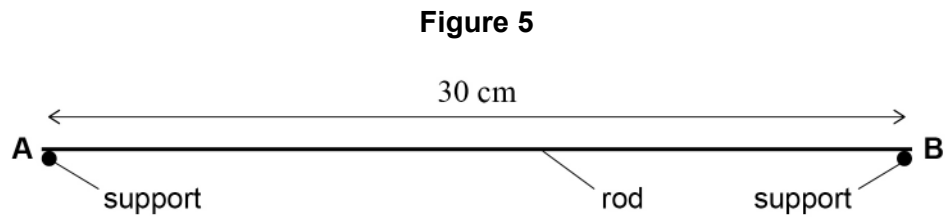

0 6 . 1

Calculate the magnitude of the force of **one** support on the rod.

[1 mark]

magnitude of force = _____ N

0 6 . 2

Explain whether the forces from the supports on the rod produce a couple.

[2 marks]

0 6 . 3

State the principle of moments.

[2 marks]



The rod is now bent through an angle θ at **X** as shown in **Figure 6**.
When the rod is balanced on a single support at **X**, section **AX** is horizontal.

length of **AX** = 10 cm

length of **XB** = 20 cm

Figure 6

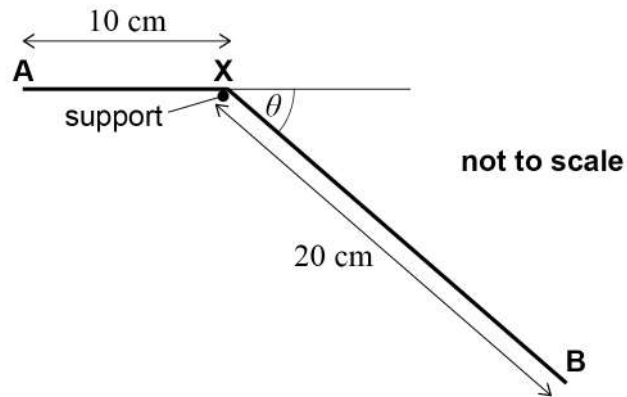

0 6 . 4 Calculate θ .

[3 marks]

$\theta =$ _____ degrees

8

Turn over ►



0 7

A system designed to store energy uses a large load suspended from four steel ropes in an underground vertical tunnel. Energy is stored when the load is lifted.

Figure 7

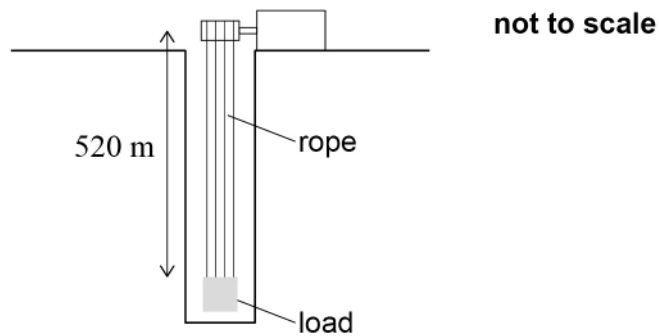

0 7 . 1

Figure 8 shows a vernier caliper measuring the maximum width of one steel rope. The rope is made from seven identical wires.

Figure 9 shows a larger view of the scale of the caliper.

Figure 8

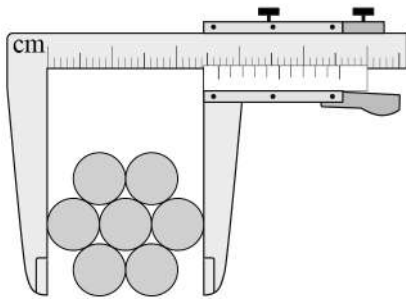
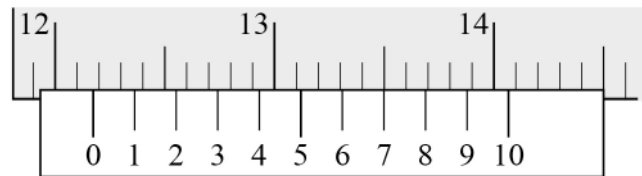

Figure 9



Show, using **Figure 9**, that the cross-sectional area of this rope is approximately $9.0 \times 10^{-3} \text{ m}^2$.

[3 marks]



0 7 . 2 **Figure 7** shows the load at its lowest point. The vertical length of each steel rope is 520 m.

Show that the total mass of the four ropes is approximately 9×10^4 kg.

$$\text{density of steel} = 4.7 \times 10^3 \text{ kg m}^{-3}$$

[2 marks]

The maximum tension in each rope is 1.4×10^6 N when the load is accelerated from its lowest point.

The mass of the load is 4.5×10^5 kg.

0 7 . 3 Calculate the acceleration of the load.

[4 marks]

acceleration = _____ m s^{-2}

Question 7 continues on the next page

Turn over ►



0 7 . 4

The breaking stress of the steel used to make the four ropes is 890 MPa.
For safety reasons, the maximum stress in each rope during the acceleration must be less than $\frac{1}{5}$ of the breaking stress.

Deduce whether these ropes are safe.

[2 marks]

0 7 . 5

It is suggested that the load and ropes will store 4 MW h of energy when the load has been lifted by 520 m.

Deduce whether this suggestion is correct.

[4 marks]

15**END OF SECTION A**

Section BAnswer **all** questions in this section.**0 8**

Figure 10 shows an arrangement used to investigate the inverse-square law for gamma radiation.

The count rate is measured for a range of distances d between the source and the Geiger Müller (GM) tube.

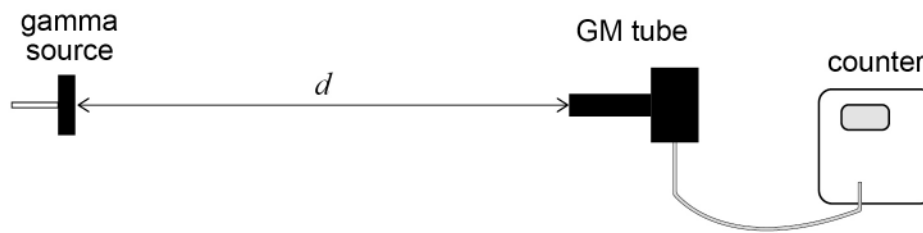
Figure 10**0 8 . 1**

A background count is determined at the start and at the end of the investigation.

Explain why.

[1 mark]

When $d = 9.0$ cm the measured count rate is 84.49 s^{-1} and the corrected count rate C_R is 84.16 s^{-1} .

0 8 . 2

Deduce the background count measured over a time period of 5 minutes.

[1 mark]

background count = _____

Question 8 continues on the next page

Turn over ►



Table 2 shows values of d , C_R and $\frac{1}{\sqrt{C_R}}$.

Table 2

d / cm	C_R / s^{-1}	$\frac{1}{\sqrt{C_R}} / \text{s}^{\frac{1}{2}}$
9.0	84.16	0.109
12.0	56.93	0.133
16.0	35.19	0.169
20.0	23.98	
24.0	18.39	
28.0	14.79	

0 8 . 3 Complete **Table 2**.

[1 mark]



Figure 11 is a plot of $\frac{1}{\sqrt{C_R}}$ against d .

Figure 11

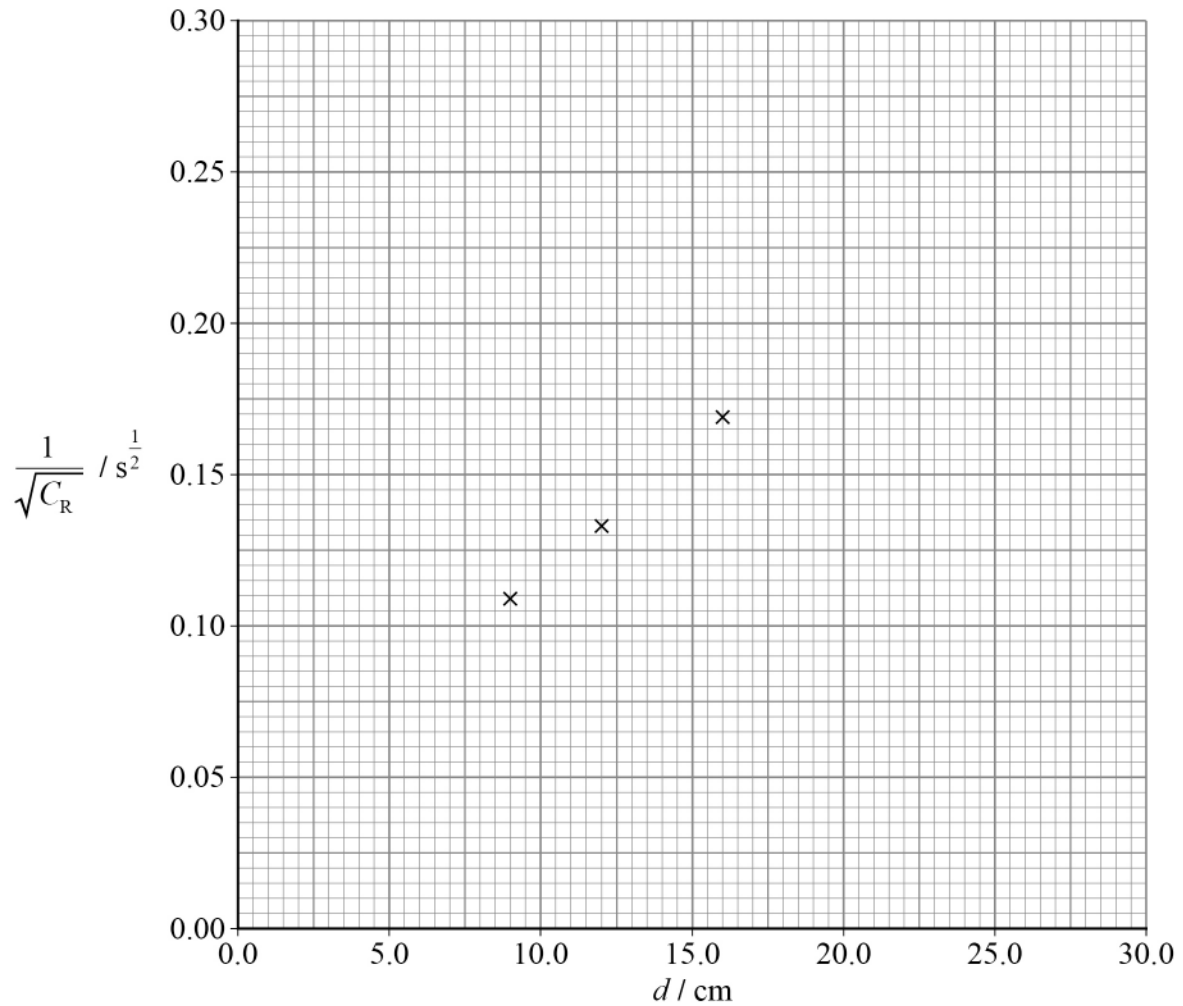

0 8 . 4 Plot on **Figure 11** the last three points from your completed **Table 2**.

[1 mark]

0 8 . 5 Draw on **Figure 11** the line of best fit.

[1 mark]

Question 8 continues on the next page

Turn over ►



0	8	.	6
---	---	---	---

Discuss whether your graph supports the inverse-square law.

[2 marks]

—
7



Turn over for the next question

*Do not write
outside the
box*

**DO NOT WRITE ON THIS PAGE
ANSWER IN THE SPACES PROVIDED**

Turn over ►



0 9

Figure 12 shows a camera above a sports field. The camera is supported by two cables **X** and **Y** that pass over smooth pulleys. **X** and **Y** have negligible mass.

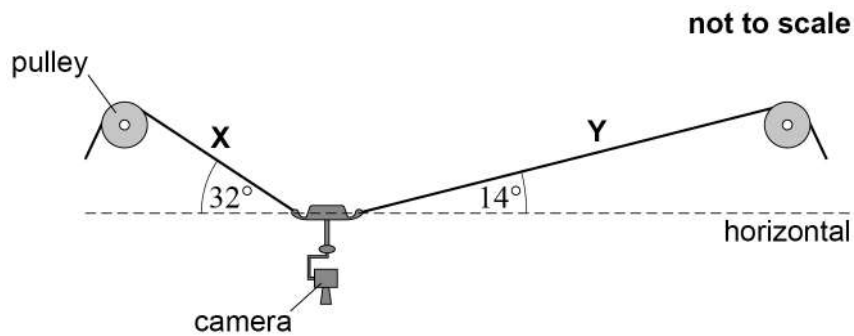
Figure 12

The camera is held stationary.

The tension in **X** is 450 N and **X** makes an angle of 32° to the horizontal.

Y makes an angle of 14° to the horizontal.

0 9 . 1

Show that the tension in **Y** is approximately 400 N.

[2 marks]

0 9 . 2 Determine, using a scale diagram, the weight of the camera.

[3 marks]

weight = _____ N

Question 9 continues on the next page

Turn over ►



0 9 . 3 Figure 13 shows the variation of stress with strain for the material used to make X.

Figure 13

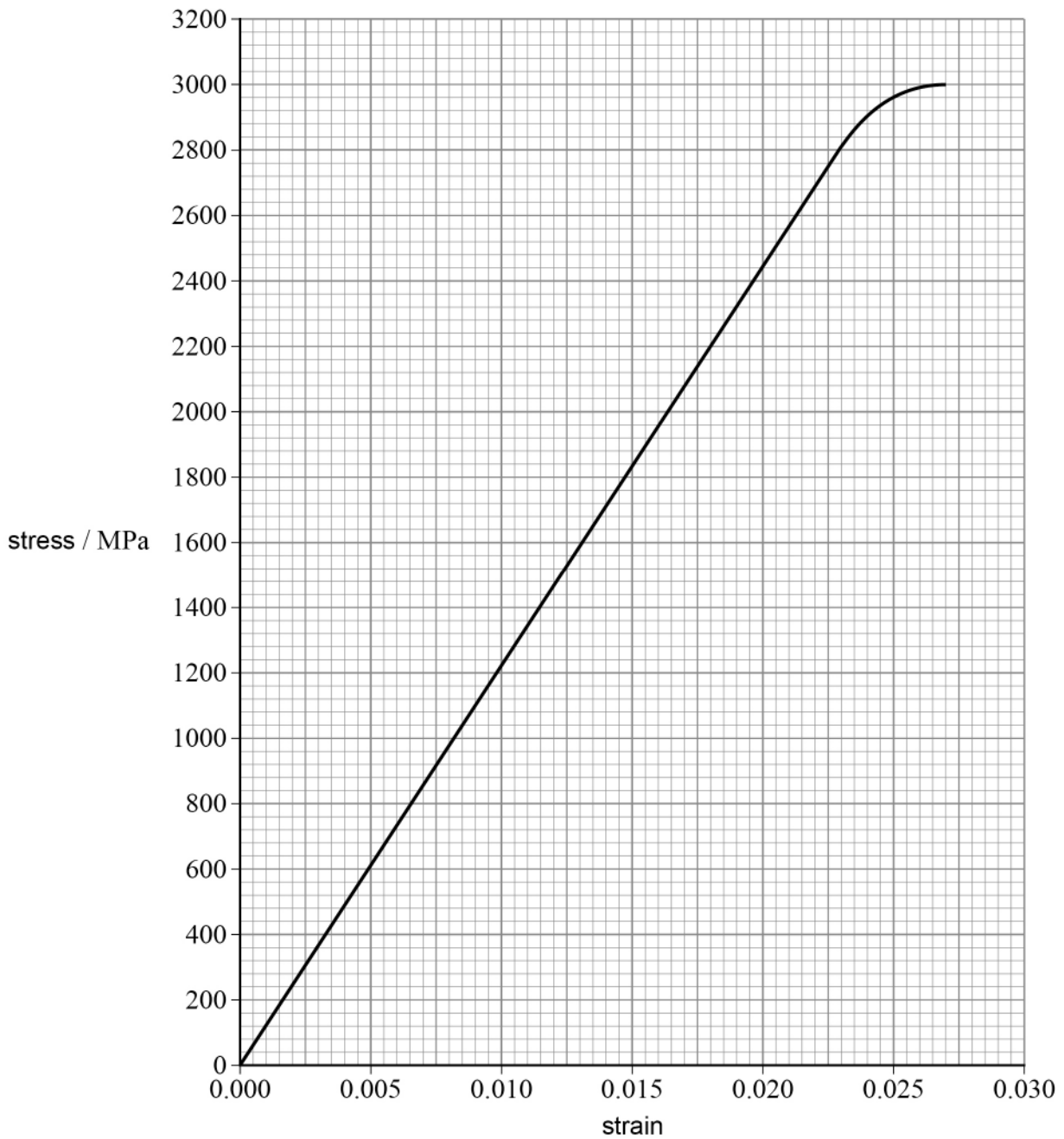

X has a cross-sectional area of $6.7 \times 10^{-6} \text{ m}^2$ and an unstretched length of 75 m.
The tension in **X** is 450 N.

Determine the extension of **X**.

[3 marks]

extension of **X** = _____ m

0 9 . 4

The camera is moved horizontally to the right to a new stationary position.

Describe the change in the tension in **X** and the change in the tension in **Y**.

[1 mark]

9

END OF SECTION B

Turn over ►



Section C

Each of the questions in this section is followed by four responses, **A**, **B**, **C** and **D**.

For each question select the best response.

Only **one** answer per question is allowed.

For each question, completely fill in the circle alongside the appropriate answer.

CORRECT METHOD



WRONG METHODS



If you want to change your answer you must cross out your original answer as shown. 

If you wish to return to an answer previously crossed out, ring the answer you now wish to select as shown. 

You may do your working in the blank space around each question but this will not be marked. Do **not** use additional pages for this working.

1 0

A father pulls his child in a trolley at a constant speed of 2.0 m s^{-1} across a flat surface.

The father exerts a force of 70 N on the handle of the trolley for 2 minutes.

The handle of the trolley is at an angle of 55° to the vertical.

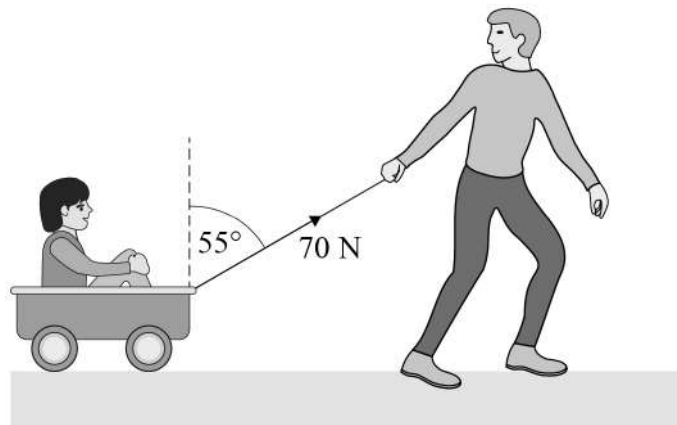

What is the work done by the father against the resistive forces that act on the trolley?

[1 mark]

A 9.6 kJ

B 14 kJ

C 17 kJ

D 21 kJ



1 1 Which row shows two scalar quantities and one vector quantity?

[1 mark]

A	momentum	mass	velocity	<input type="radio"/>
B	acceleration	speed	time	<input type="radio"/>
C	work done	force	displacement	<input type="radio"/>
D	power	velocity	force	<input type="radio"/>

1 2 An object with mass m falls through the air with a terminal speed v .

How much energy is transferred to the air in time t ?

[1 mark]

A $mg t$

B $mgvt$

C $\frac{mv}{t}$

D mvt

1 3 A motor is supplied with 5.2 kJ of energy in 2.5 minutes.
The efficiency of the motor is 35%.

What is the useful power output of the motor?

[1 mark]

A 12 W

B 23 W

C 73 W

D 99 W

Turn over ►



1 4

An object is launched at an initial velocity of u at an angle of θ to the horizontal.

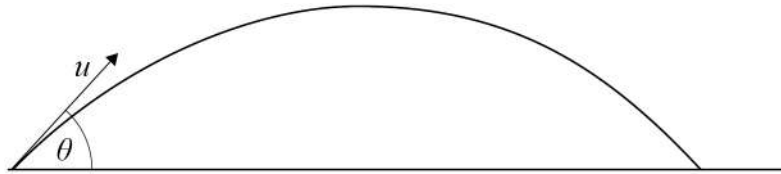

The initial vertical displacement of the object is zero.

At time T , the vertical displacement of the object becomes zero again.

The effect of air resistance is negligible.

What is the vertical component of the velocity of the object at time T ?

[1 mark]

A $-u\sin\theta$

B $-u\cos\theta$

C $u\sin\theta$

D $u\cos\theta$

1 5

An unpowered rollercoaster car is released from rest and descends through a height of 55 m.

What is the maximum possible speed of the car?

[1 mark]

A 11 m s^{-1}

B 16 m s^{-1}

C 23 m s^{-1}

D 33 m s^{-1}



1 6

Three identical objects **P**, **Q** and **R** leave the edge of a table at the same time.

P is released from rest and falls vertically.

Q and **R** are projected horizontally at different speeds.

The objects move in parallel vertical planes.

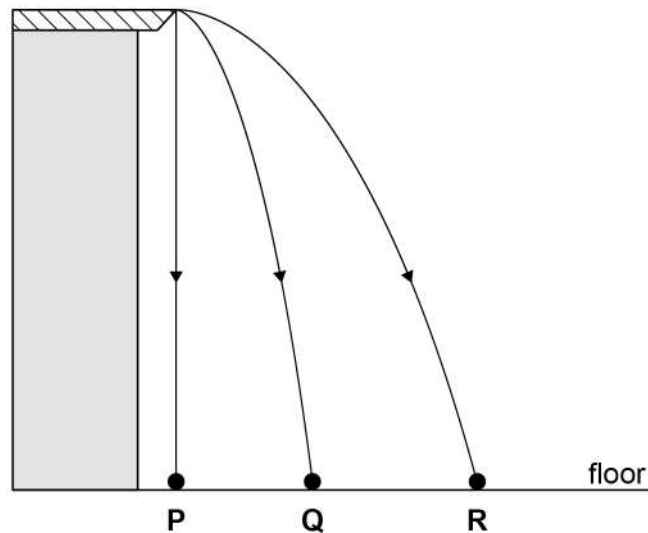

Which statement is correct?

[1 mark]

- A** **P** hits the floor before **Q** and **R**.
- B** **Q** hits the floor before **R**.
- C** **Q** hits the floor with the same speed as **R**.
- D** **R** hits the floor with the greatest speed.

Turn over for the next question

Turn over ►



1 7

An atom travelling at speed v collides elastically with the wall of a container.

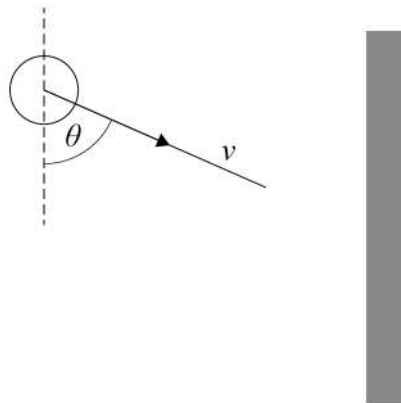

Which diagram shows the change in velocity Δv of the atom for the collision?

[1 mark]

A

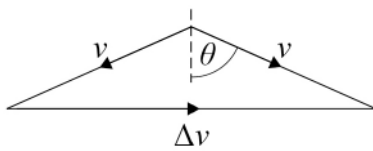

B



C

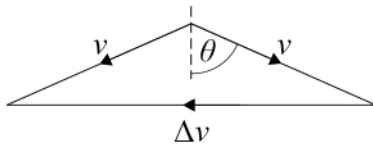

D

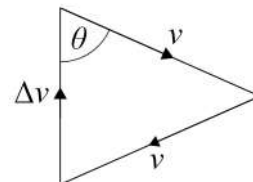
A B C D 

1 8Three coplanar forces F_1 , F_2 and F_3 act on a point object.Which combination of these forces **cannot** produce a resultant force of zero?**[1 mark]**

	F_1	F_2	F_3	
A	1	10	10	<input type="radio"/>
B	6	8	10	<input type="radio"/>
C	10	10	10	<input type="radio"/>
D	2	7	10	<input type="radio"/>

Turn over for the next question**Turn over ►**

1 9

A wire obeys Hooke's law. When an applied force F acts on the wire, the extension is x and the energy stored in the wire is E .

Which pair of graphs is correct?

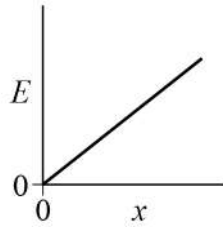
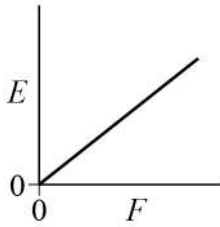
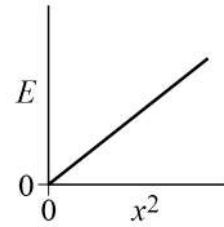
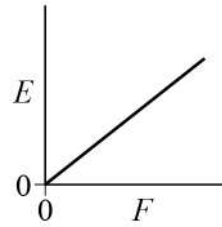
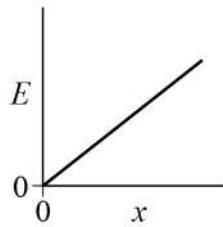
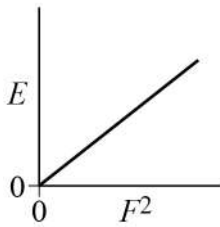
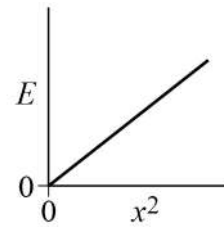
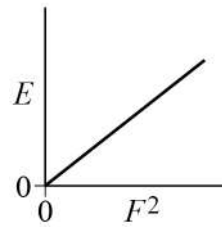
[1 mark]**A****B****C****D****A** **B** **C** **D** 

2 0

The graph shows the variation of strain with stress for two materials **X** and **Y** up to the points at which they break.

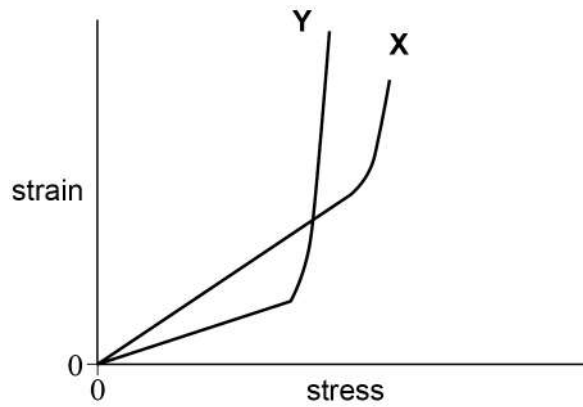

Which row is correct?

[1 mark]

	Material with greater Young modulus	Material with greater breaking stress	
A	X	X	<input type="checkbox"/>
B	X	Y	<input type="checkbox"/>
C	Y	X	<input type="checkbox"/>
D	Y	Y	<input type="checkbox"/>

Turn over for the next question

Turn over ►



2 1

A nucleus of lead deflects an alpha particle with a force F .

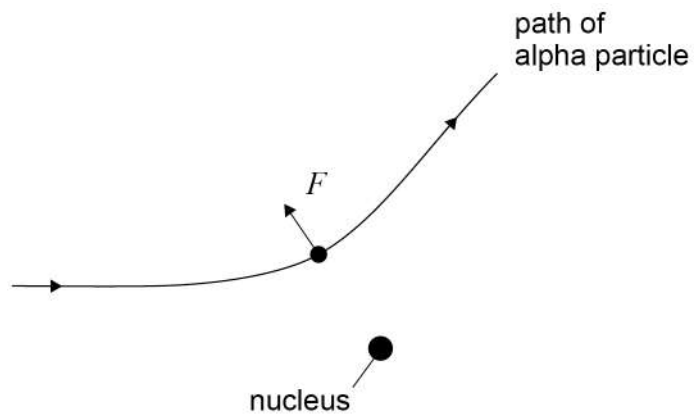

At the instant shown in the diagram, the force exerted by the alpha particle on the lead nucleus has a magnitude that is

[1 mark]

- A** zero.
- B** less than the magnitude of F .
- C** equal to the magnitude of F .
- D** greater than the magnitude of F .



2 2

When each nucleus in a radioactive source decays, 8.8×10^{-13} J of energy is released.

The source has a half-life of 90 years and an initial activity of 60 MBq.

What power will be available from the source after 270 years?

[1 mark]

A 6.6×10^{-7} W

B 6.6×10^{-6} W

C 1.3×10^{-5} W

D 1.8×10^{-5} W

2 3

A nuclide decays through a radioactive decay chain.

Four β^- particles and two α particles are emitted.

The final nuclide

[1 mark]

A has a higher proton number than the original nuclide.

B has the same nucleon number as the original nuclide.

C has the same proton number as the original nuclide.

D has a higher nucleon number than the original nuclide.

14**END OF QUESTIONS**

There are no questions printed on this page

*Do not write
outside the
box*

**DO NOT WRITE ON THIS PAGE
ANSWER IN THE SPACES PROVIDED**



