

OCR

Oxford Cambridge and RSA

F**Tuesday 23 November 2021 – Morning****GCSE (9–1) Physics A (Gateway Science)****J249/01 Paper 1 (Foundation Tier)****Time allowed: 1 hour 45 minutes****You must have:**

- a ruler (cm/mm)
- the Data Sheet for GCSE (9–1) Physics A (inside this document)

You can use:

- a scientific or graphical calculator
- an HB pencil

Please write clearly in black ink. **Do not write in the barcodes.**

Centre number

--	--	--	--	--	--

Candidate number

--	--	--	--

First name(s)

Last name

INSTRUCTIONS

- Use black ink. You can use an HB pencil, but only for graphs and diagrams.
- Write your answer to each question in the space provided. If you need extra space use the lined pages at the end of this booklet. The question numbers must be clearly shown.
- Answer **all** the questions.
- Where appropriate, your answer should be supported with working. Marks might be given for using a correct method, even if your answer is wrong.

INFORMATION

- The total mark for this paper is **90**.
- The marks for each question are shown in brackets [].
- Quality of extended response will be assessed in questions marked with an asterisk (*).
- This document has **28** pages.

ADVICE

- Read each question carefully before you start your answer.

2
SECTION A

Answer **all** the questions.

You should spend a maximum of 30 minutes on this section.

Write your answer to each question in the box provided.

1 Which of the following would you find in the nucleus of an atom?

- A Neutrons and electrons
- B Neutrons, electrons and protons
- C Protons and electrons
- D Protons and neutrons

Your answer

[1]

2 Two charged rods are brought close together.



Which of the following explains what happens to the rods?

- A Like charges attract so the rods move towards each other.
- B Like charges repel so the rods move away from each other.
- C Opposite charges attract so the rods move towards each other.
- D Opposite charges repel so the rods move away from each other.

Your answer

[1]

3

3 A student does an experiment to measure the acceleration in free fall of an object.

Which of their results is closest to the accepted value?

- A 8.8m/s^2
- B 9.8m/s^2
- C 10.8m/s^2
- D 11.8m/s^2

Your answer

[1]

4 Which row in the table correctly identifies a scalar and a vector?

	Scalar	Vector
A	Displacement	Distance
B	Displacement	Velocity
C	Distance	Speed
D	Speed	Velocity

Your answer

[1]

5 Which of the following is an example of a chemical change?

- A Burning
- B Evaporating
- C Melting
- D Sublimating

Your answer

[1]

4

- 6 A current of 8A flows in a circuit for 32 seconds.

Calculate the charge which flows in the circuit.

Use the equation: charge flow = current \times time

- A 0.25C
- B 4.0C
- C 24.0C
- D 256C

Your answer

[1]

- 7 Which statement explains why the atomic model has changed over time?

- A Models can explain different situations.
- B Models can only be used for a limited time period.
- C New information is discovered.
- D Scientists are paid to keep changing models.

Your answer

[1]

- 8 Which force is **not** a contact force?

- A Air resistance
- B Friction
- C Gravitational
- D Tension

Your answer

[1]

5

9 Four velocity–time graphs are shown for a moving ball.

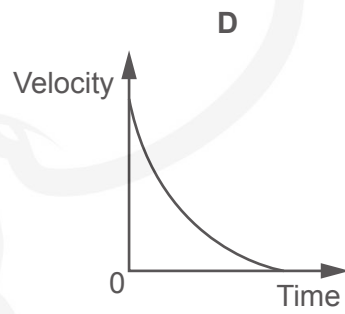
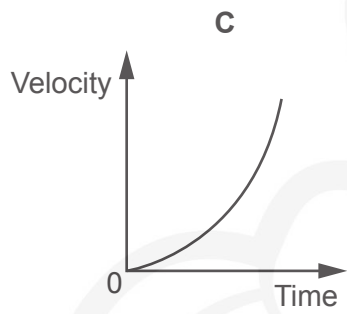
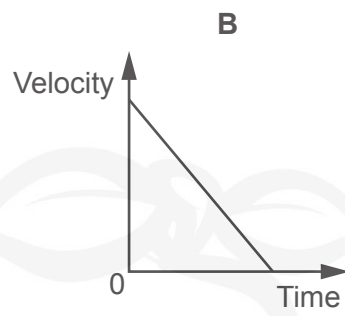
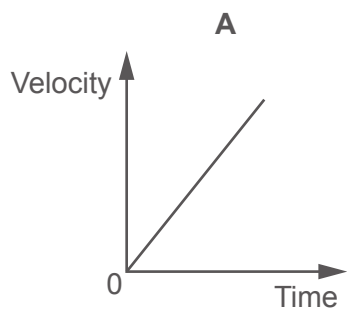

Which graph shows the ball being dropped from a height? Ignore the effects of air resistance.

Your answer

[1]

6

10 A girl, of weight 400 N, is standing on the end of a horizontal diving board.

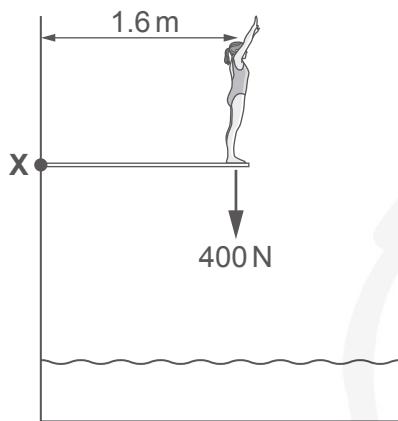

Calculate the moment of the girl's weight about point X.

Use the equation: moment of a force = force \times distance

- A 250 Nm anti-clockwise
- B 250 Nm clockwise
- C 640 Nm anti-clockwise
- D 640 Nm clockwise

Your answer

[1]

- 11 Gears can be used to transmit forces.

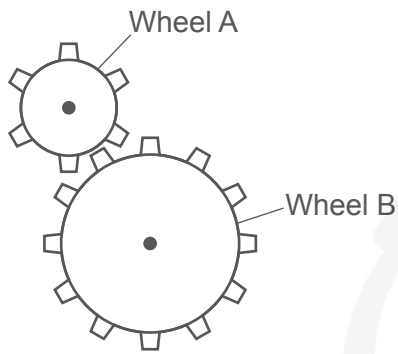

Wheel A is turned clockwise.

Which statement explains how these gears transmit forces?

- A Wheel B has a bigger rotational effect and turns more quickly than wheel A.
- B Wheel B has a bigger rotational effect and turns more slowly than wheel A.
- C Wheel B has a smaller rotational effect and turns more quickly than wheel A.
- D Wheel B has a smaller rotational effect and turns more slowly than wheel A.

Your answer

[1]

- 12 A book of mass 3 kg is lifted vertically onto a shelf 1.5 m high.

Calculate the gain in potential energy of the book.

Assume gravitational field strength = 10 N/kg.

Use the equation: potential energy = mass \times height \times gravitational field strength

- A 0.45 J
- B 5.0 J
- C 20 J
- D 45 J

Your answer

[1]

13 A teacher evaporates 50 g of water. They collect all of the steam and condense it back into water.

Which statement is true?

- A The mass of the steam produced is less than 50 g.
- B The mass of the steam produced is more than 50 g.
- C The mass of the water at the end is 50 g.
- D The mass of the water at the end is less than 50 g.

Your answer

[1]

14 A teacher sets up a circuit to turn on a heater when the temperature decreases.

Which component does the teacher need to use in their circuit?

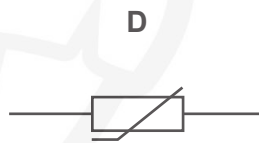
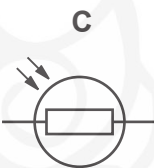
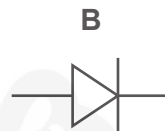

Your answer

[1]

15 The specific latent heat of fusion for lead is 24 500 J/kg.

Calculate the thermal energy required for 0.2 kg of lead to melt.

Use an equation from the data sheet to help you.

- A 2450 J
- B 4900 J
- C 12250 J
- D 122500 J

Your answer

[1]



PLEASE DO NOT WRITE ON THIS PAGE

SECTION B

Answer **all** the questions.

16 A group of students investigate magnetic fields.

(a) Fig. 16.1 shows the magnetic field around a bar magnet.

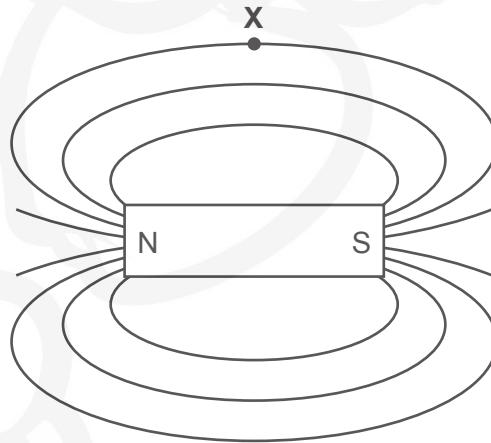

Fig. 16.1

Draw an arrow on the field line at position X on Fig. 16.1 to show the direction of the magnetic field. [1]

(b) A current in a wire creates a magnetic field. A straight wire carrying an electric current passes through a flat card as shown in Fig. 16.2.

(i) Draw on Fig. 16.2 the shape and direction of the magnetic field observed on the card. [2]

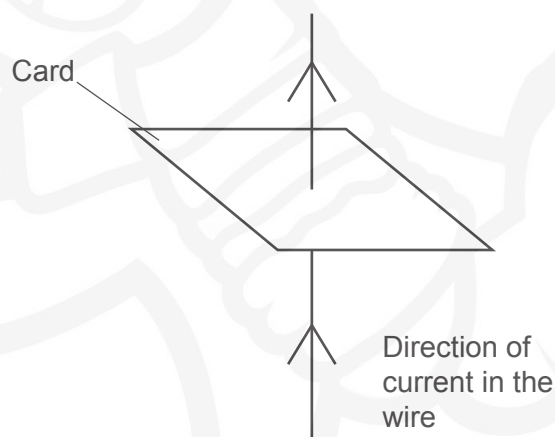

Fig. 16.2

(ii) Suggest **one** way the students could increase the strength of the magnetic field around the wire.

..... [1]

- (c) The students investigate the strength of an electromagnet. They change the number of turns on the electromagnet and count how many paperclips it can pick up.

The students record their data in a table.

Number of turns	Number of paperclips picked up
0	0
10	3
20	6
30	10
40	12
50	14

- (i) Plot the **two** missing results onto the graph.

Draw a line of best-fit.

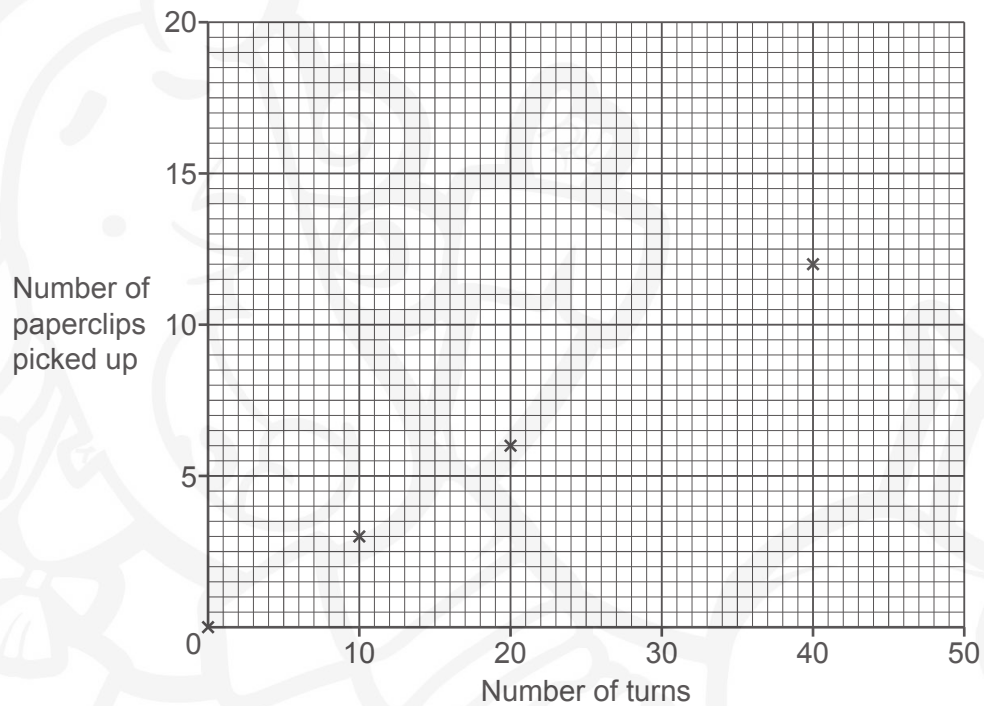

[3]

- (ii) Describe the relationship between the number of turns and the number of paperclips picked up. You may use data from the graph in your answer.

.....

.....

..... [2]

- (iii) Suggest **two** variables the students need to control in their experiment.

1

2

[2]

17 A student sets up a circuit using a diode, a lamp and a variable resistor, as shown in Fig. 17.1.

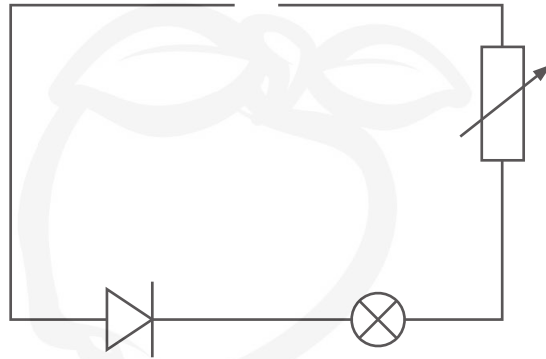

Fig. 17.1

Draw a cell in the circuit on Fig. 17.1 so that the lamp would light up.

[2]

18 This question is about gas pressure.

(a) Complete each sentence to explain how temperature affects the pressure of a gas.

You can use each word once, more than once, or not at all.

area distance energy pressure speed

When the temperature of a gas increases, the particles have a greater average
..... and a greater average

The particles now collide more often with the sides of the container. More frequent collisions
over a fixed area produce a greater [3]

(b) A student investigates how pressure and volume are linked for a gas at a fixed temperature.

Their results are shown in **Table 18.1**.

Pressure (kPa)	Volume (cm ³)
200	50
250	40
400	25
1000	10

Table 18.1

The student suggests that **pressure × volume = constant**

Use the data in **Table 18.1** to work out if the student is correct.

.....

 [3]

(c) Explain why atmospheric pressure **decreases** with height above the surface of the Earth.

.....
 [1]

19 Newton-meters are used for measuring forces. Each newton-meter contains a spring.

(a) What is the minimum number of forces needed to stretch a spring?

..... [1]

(b) A student has three different newton-meters.

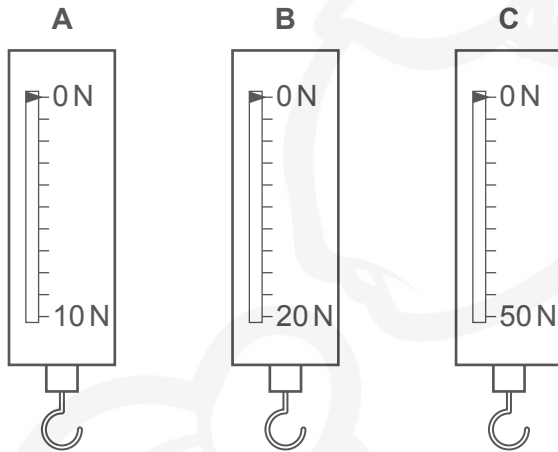

(i) Which newton-meter would be best to use to measure a force of about 11 N?

.....

Explain your answer.

..... [2]

(ii) Explain what could happen if a 50 N weight was put on newton-meter A.

..... [2]

(iii) Which newton-meter has the **largest** spring constant?

.....

Explain your answer.

..... [2]

- (c) Another student suggests that an elastic band could be used instead of a spring in a newton-meter.

Look at the force-extension graph for an elastic band.

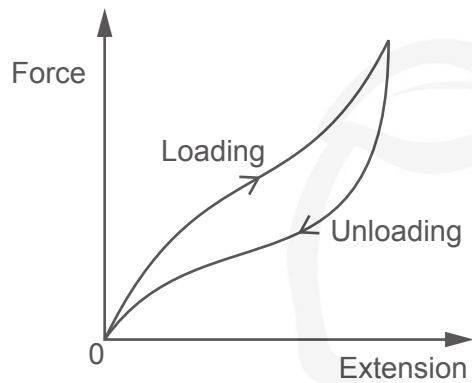

Explain why the elastic band would **not** make a good replacement for a spring.

.....

.....

.....

..... [2]

- (d) A spring has a spring constant of 30 N/m.

Calculate the energy transferred when the spring is extended by 4.0 cm.

Use an equation from the data sheet to help you.

Energy transferred = J [3]

20* A group of students want to determine the density of two small objects, **A** and **B**.

A is a regular cube made of iron and **B** is an irregular-shaped object made of copper.

A

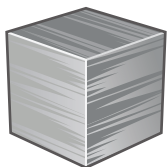

B

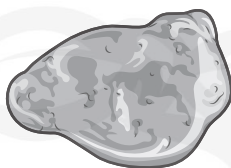

Describe the methods that the students would use to determine the density of iron and copper.

In your answer include:

- Equipment and equations that they would use.
- How they would make sure that their results are accurate and precise.

.....

[6]



PLEASE DO NOT WRITE ON THIS PAGE

21 Different planets have different gravitational field strengths at their surface.

Planet	Gravitational field strength (N/kg)
Earth	10
Mars	3.7
Venus	8.8

(a) (i) On which planet's surface would an astronaut have the greatest weight?

Surface

Explanation

..... [2]

(ii) Which property of a planet affects its gravitational field strength?

..... [1]

(b) (i) On Earth the astronaut has a weight of 600N. Their feet have a total area of 0.3m² in contact with the ground.

Calculate the pressure they exert on the ground.

Pressure =N/m² [3]

19

(ii) The astronaut is standing on the ground. Two forces acting on them are:

- The force exerted by the Earth (their weight).
- The force exerted by the ground (normal contact force).

Draw and label a free body force diagram for the astronaut.



[3]

- 22 (a) A delivery driver is loading boxes onto a lorry. The boxes are moved from the ground to the lorry using an electric lift.



- (i) Calculate the work done when boxes with a weight of 0.6 kN are lifted a vertical distance of 0.8 m from the ground to the lorry.

Use the equation: work done = force \times distance

Work done = J [3]

- (ii) The power of the lift is 50 W.

Calculate the time taken for the lift to move these boxes from ground to lorry level.

Use the equation: power = work done / time taken

Time taken = s [3]

- (iii) The lorry uses a 24 V battery to power the 50 W lift.

Calculate the current which flows while the lift is in use.

Use the equation: power = potential difference \times current

Give your answer to **2** significant figures.

Current = A [4]

21
BLANK PAGE



PLEASE DO NOT WRITE ON THIS PAGE

23 A student travels to a friend's house. This is a distance–time graph of their journey.

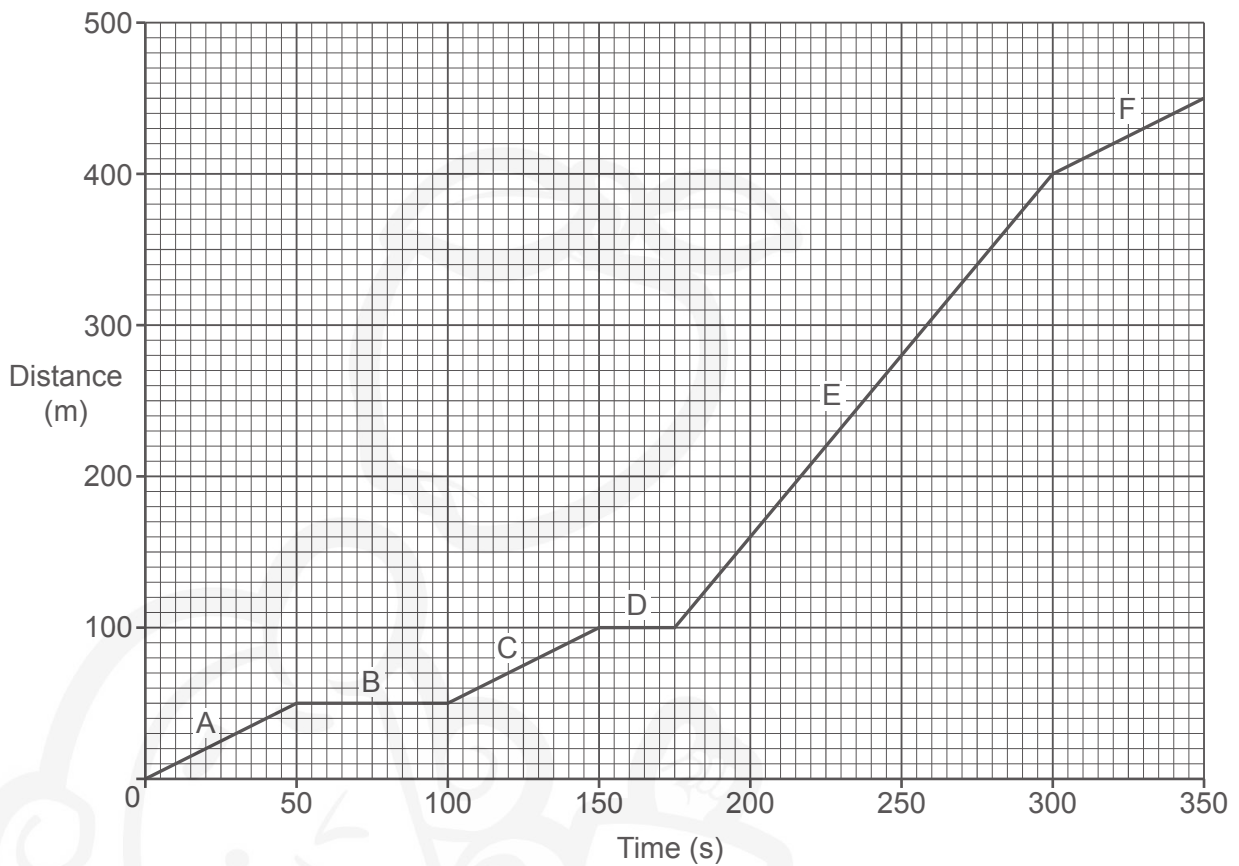

(a) (i) State the total distance travelled by the student to their friend's house.

..... [1]

(ii) State the total time it takes the student to get to their friend's house.

..... [1]

(iii) Calculate the student's average speed during their journey.

Use the equation: distance travelled = speed × time

Average speed = m/s [3]

(iv) State which section of the journey, **A–F**, is where the student travels fastest. Explain your answer.

Section

Explanation

.....

[2]

(v) Suggest what happens at sections **B** and **D** on the journey.

..... [1]

(b) Suggest which equipment the student can use to measure the time and distance on their journey.

Time

Distance

..... [1]

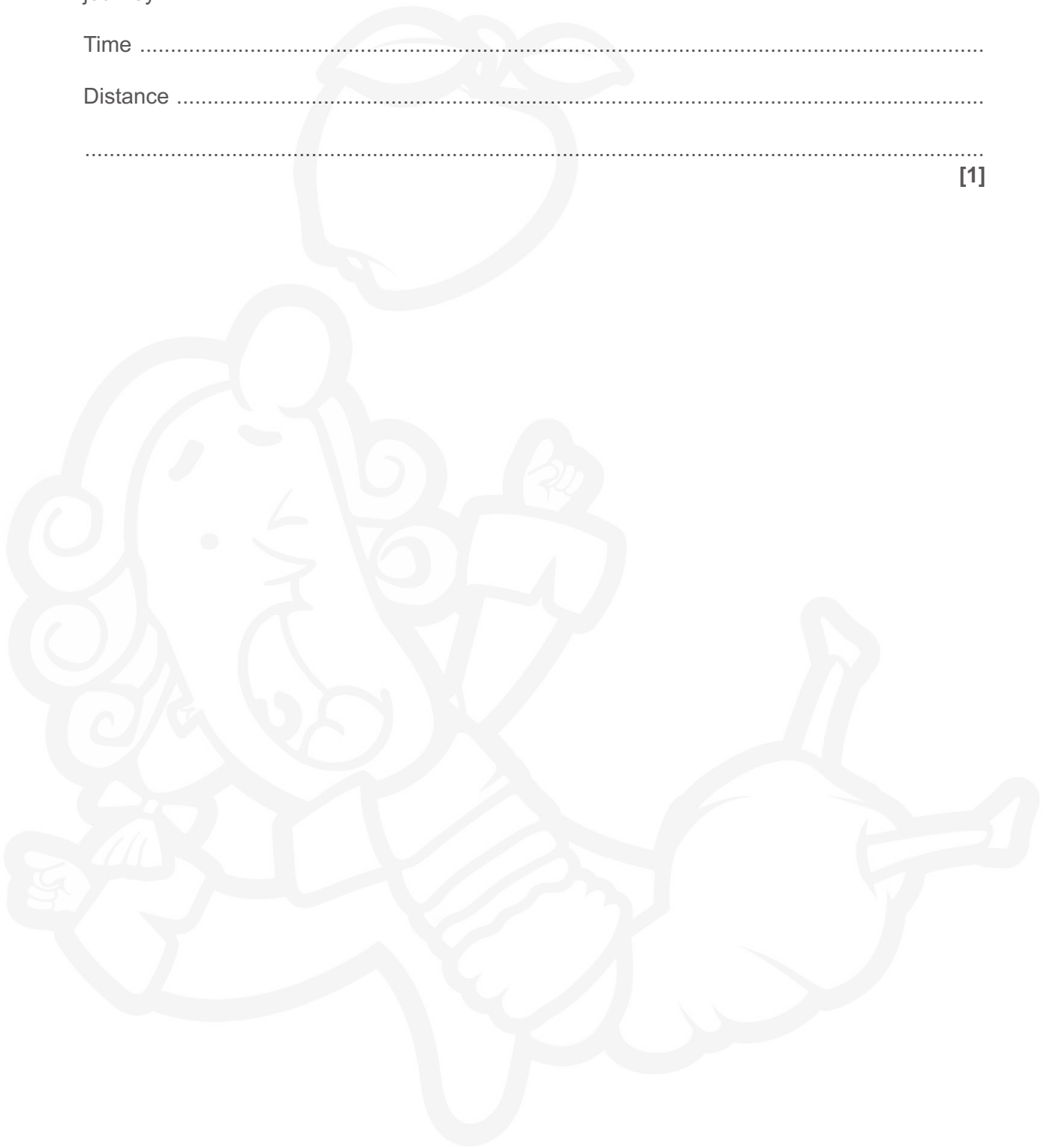

24 A student does an experiment to calculate the resistance of an unknown component, Y.

The student sets up the circuit in Fig. 24.1.

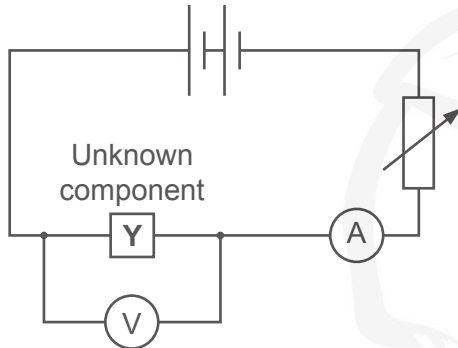

Fig. 24.1

(a) The student needs to be able to measure a current of up to 1 A.

The student has a choice of two different ammeters to use, ammeter A and ammeter B.

Fig. 24.2 shows the initial readings on the ammeters **before** they are connected to the circuit.

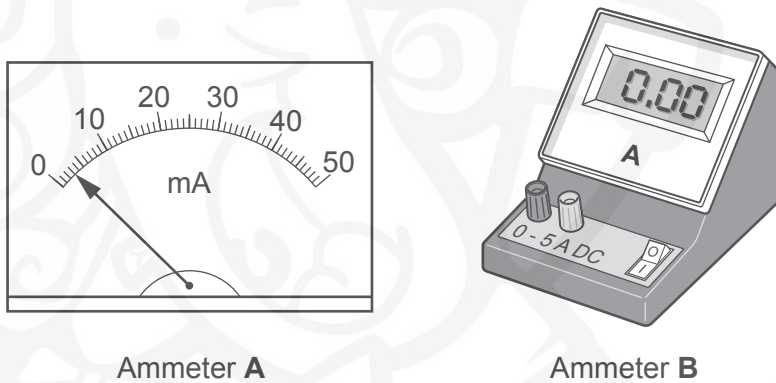

Fig. 24.2

Which ammeter is best for the student to use? Give **two** reasons.

Ammeter

Reason 1

.....

Reason 2

.....

[2]

- (b) The student takes readings of potential difference and current for component Y and plots them on a graph.

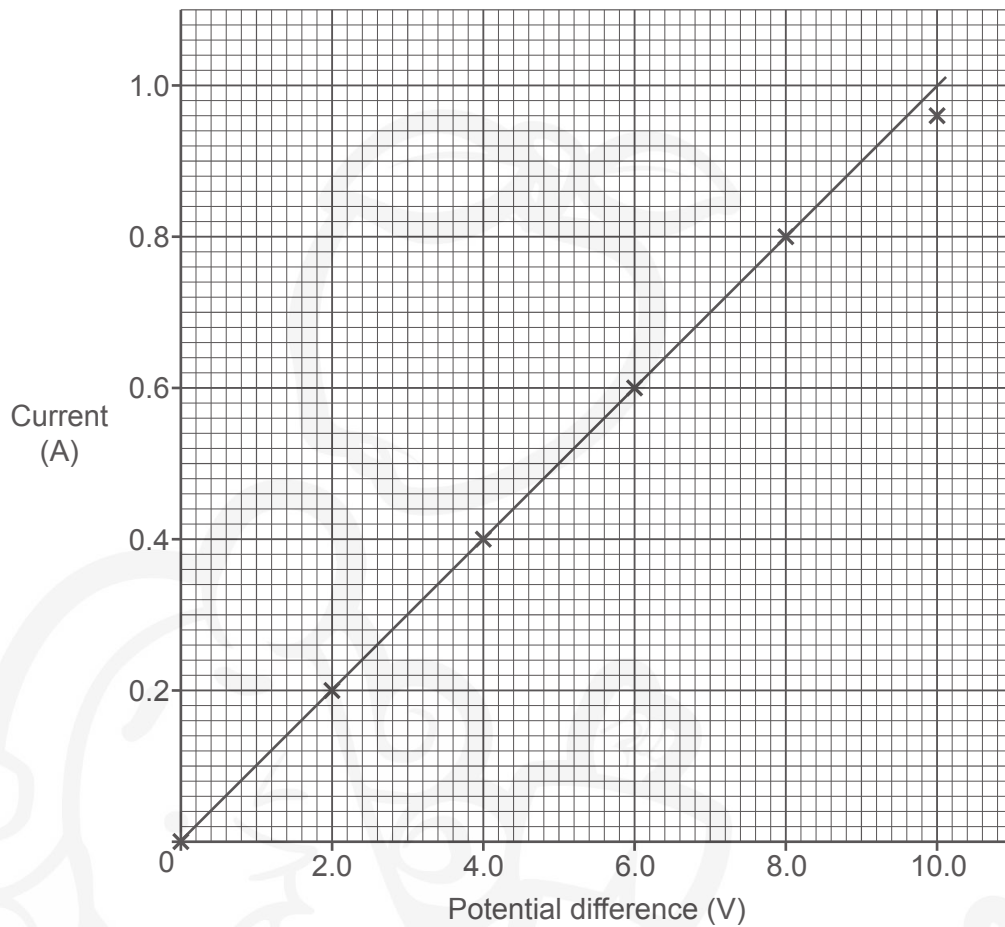

- (i) Explain why the student thinks that component Y is a fixed resistor.

.....

.....

.....

.....

[2]

- (ii) The student has correctly plotted the point at 10.0V on the graph.

Suggest **one** reason why the point is not on the line of best-fit.

.....

.....

[1]

(iii) Suggest **two** ways the student can check if their results are reproducible.

1

.....

2

.....

[2]

(c) The resistor has a resistance of 10.0Ω .

Calculate the power of the resistor when the current is 0.5A .

Use the equation: $\text{power} = (\text{current})^2 \times \text{resistance}$

Power = W [2]

END OF QUESTION PAPER

ADDITIONAL ANSWER SPACE

If additional space is required, you should use the following lined page(s). The question number(s) must be clearly shown in the margin(s).

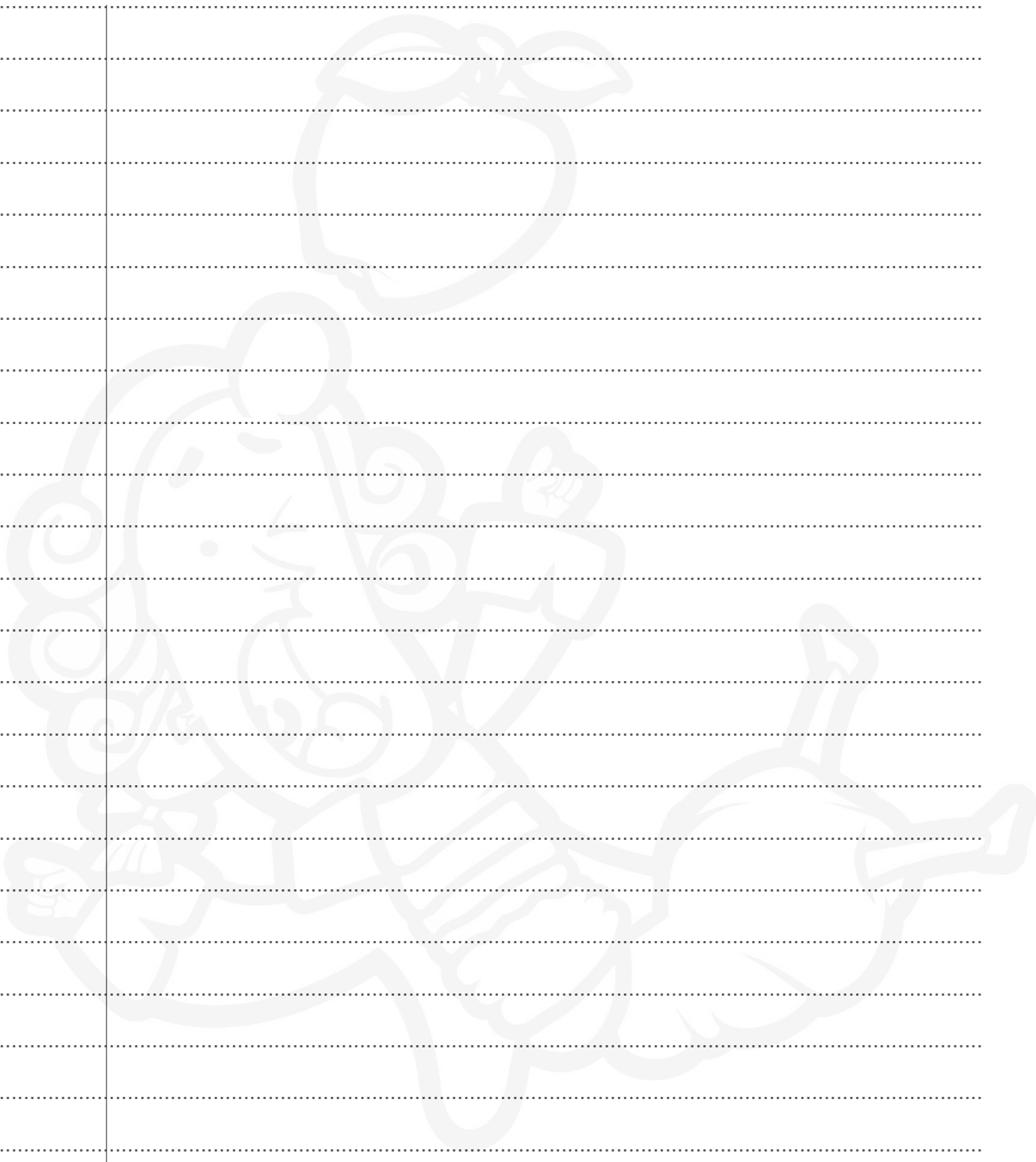

A large, faint watermark illustration of a cartoon character with a large head, wearing a turban and a dhoti, holding a book. The character is positioned in the center of the page, behind the lined writing area.

A large writing area consisting of a vertical line on the left and horizontal dotted lines extending across the page, intended for students to write their answers.

OCR
Oxford Cambridge and RSA

Copyright Information

OCR is committed to seeking permission to reproduce all third-party content that it uses in its assessment materials. OCR has attempted to identify and contact all copyright holders whose work is used in this paper. To avoid the issue of disclosure of answer-related information to candidates, all copyright acknowledgements are reproduced in the OCR Copyright Acknowledgements Booklet. This is produced for each series of examinations and is freely available to download from our public website (www.ocr.org.uk) after the live examination series. If OCR has unwittingly failed to correctly acknowledge or clear any third-party content in this assessment material, OCR will be happy to correct its mistake at the earliest possible opportunity.

For queries or further information please contact The OCR Copyright Team, The Triangle Building, Shaftesbury Road, Cambridge CB2 8EA.

OCR is part of the Cambridge Assessment Group; Cambridge Assessment is the brand name of University of Cambridge Local Examinations Syndicate (UCLES), which is itself a department of the University of Cambridge.