



Oxford Cambridge and RSA

Friday 8 October 2021 – Morning

A Level Physics A

H556/01 Modelling physics

Time allowed: 2 hours 15 minutes



You must have:

- the Data, Formulae and Relationships Booklet

You can use:

- a scientific or graphical calculator
- a ruler (cm/mm)



Please write clearly in black ink. **Do not write in the barcodes.**

Centre number

--	--	--	--	--

Candidate number

--	--	--	--

First name(s)

Last name

INSTRUCTIONS

- Use black ink. You can use an HB pencil, but only for graphs and diagrams.
- Write your answer to each question in the space provided. If you need extra space use the lined pages at the end of this booklet. The question numbers must be clearly shown.
- Answer **all** the questions.
- Where appropriate, your answer should be supported with working. Marks might be given for using a correct method, even if your answer is wrong.

INFORMATION

- The total mark for this paper is **100**.
- The marks for each question are shown in brackets [].
- Quality of extended response will be assessed in questions marked with an asterisk (*).
- This document has **28** pages.

ADVICE

- Read each question carefully before you start your answer.

2
SECTION A

You should spend a maximum of 30 minutes on this section.

Write your answer to each question in the box provided.

Answer **all** the questions.

- 1 An object is moving in a straight line.

The displacement s against time t graph for this object is shown below.

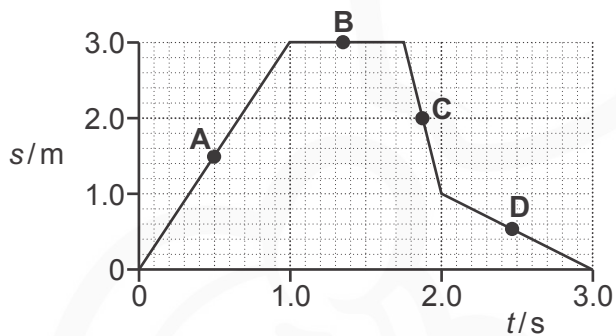

At which point **A**, **B**, **C** or **D**, does the object have the **greatest** speed?

Your answer

[1]

- 2 Which one of the following prefixes represents the **smallest** multiplication factor?

- A femto (f)
- B micro (μ)
- C nano (n)
- D pico (p)

Your answer

[1]

3

- 3 The table shows some data for a car travelling on a straight road with an initial speed of 13 m s^{-1} .

Thinking distance/m	9.0
Braking distance/m	14
Stopping distance/m	23

The car has a constant deceleration when the brakes are applied.

What is the magnitude of the deceleration of the car during braking?

- A 0.46 m s^{-2}
- B 3.7 m s^{-2}
- C 6.0 m s^{-2}
- D 9.4 m s^{-2}

Your answer

[1]

- 4 The freezing point of ethanol is 159 K .

What is 159 K in $^{\circ}\text{C}$?

- A -432°C
- B -114°C
- C 114°C
- D 432°C

Your answer

[1]

4

- 5 A spectral line corresponds to a wavelength λ_1 in the laboratory. The same spectral line observed in the spectrum of a receding galaxy corresponds to a wavelength λ_2 . The distance of the galaxy from the Earth is d . The speed of light in a vacuum is c .

What is the correct expression for the Hubble constant H_0 ?

- A $H_0 \approx \frac{c(\lambda_2 - \lambda_1)}{d\lambda_1}$
- B $H_0 \approx \frac{c\lambda_1}{d(\lambda_2 - \lambda_1)}$
- C $H_0 \approx \frac{c\lambda_2}{d\lambda_1}$
- D $H_0 \approx \frac{c\lambda_1}{d\lambda_2}$

Your answer

[1]

- 6 For a simple harmonic oscillator, the maximum speed is v_{\max} when the amplitude is A . The frequency of the oscillations is f .

Which expression is correct for this oscillator?

- A $v_{\max} = fA$
- B $v_{\max} = 2\pi fA$
- C $v_{\max} = f^2A$
- D $v_{\max} = 4\pi^2 f^2 A$

Your answer

[1]

5

- 7 The planet Mercury has a highly elliptical orbit around the Sun.

The gravitational force F acting on Mercury due to the Sun varies with its distance r from the centre of the Sun. The graph of F against r for Mercury in its orbit is shown below.

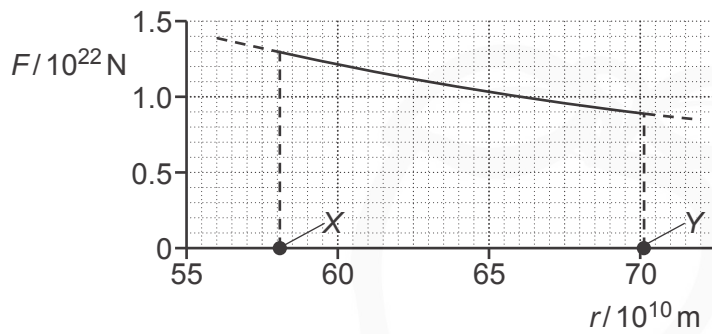

Mercury is closest to the Sun when $r = X$ and furthest when $r = Y$.

What does the **area** under the graph between the distances X and Y represent?

- A The centripetal force acting on Mercury.
- B The change in the gravitational potential energy of Mercury.
- C The impulse of the force acting on Mercury.
- D The kinetic energy of Mercury.

Your answer

[1]

6

- 8 An object of weight W is suspended from two identical cables.

The tension in each cable is 2.0 N. Each cable makes an angle of 35° to the vertical.

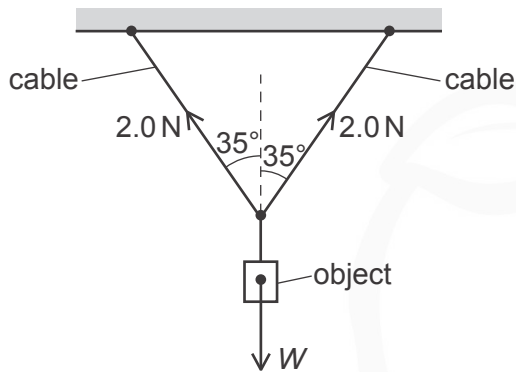

What is the weight W of the object?

- A 1.6 N
- B 2.3 N
- C 2.8 N
- D 3.3 N

Your answer

[1]

- 9 A piston has a fixed amount of trapped ideal gas.

The gas exerts pressure p and has volume V . The thermodynamic (absolute) temperature of the gas is T . The mass of each atom is m . There are N atoms of the gas. The Boltzmann constant is k .

What quantities are required to determine the root mean square speed $\sqrt{c^2}$ of the atoms?

- A k and T
- B p and V
- C p , V and T
- D p , V , N and m

Your answer

[1]

- 10 An object of mass 0.12 kg is lifted through a height of 0.60 m at a constant speed 3.0 ms^{-1} .

What is the minimum power needed to lift the object?

- A 0.36 W
- B 0.54 W
- C 3.5 W
- D 4.1 W

Your answer

[1]

- 11 Kepler-90 is a star with several planets orbiting it. The two outermost planets are Kepler-90g and Kepler-90h. Kepler-90g has an orbital period of 210 days and is 0.71 AU from the centre of Kepler-90. Kepler-90h is 1.01 AU from the centre of Kepler-90.

Kepler's third law of planetary motion can be applied to the planets of Kepler-90.

What is the orbital period of Kepler-90h?

- A 50 days
- B 299 days
- C 356 days
- D 4350 days

Your answer

[1]

- 12 Oscillations of an object can either be **free** or **forced**.

Which of the following is an example of a **forced** oscillation?

- A A ball rolling to-and-fro on a curved track.
- B A loudspeaker oscillating and producing a continuous note.
- C A mass oscillating from the end of a suspended spring.
- D A pendulum bob oscillating from the end of a fixed length of string.

Your answer

[1]

13 The force F against extension x graph for a material being stretched is shown.

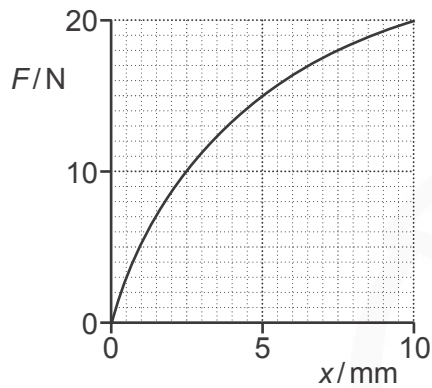

What is best estimate for the energy stored in the material when the extension is 10 mm?

- A 0.07 J
- B 0.10 J
- C 0.13 J
- D 0.20 J

Your answer

[1]

14 A ball of mass m is falling vertically through the air.

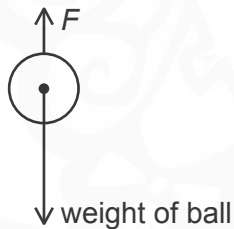

The total upward force acting on the ball is F . The force F is less than the weight of the object. The acceleration of free fall is g .

Which expression is correct for the acceleration a of the ball?

- A $a = 0$
- B $a = \frac{mg - F}{m}$
- C $a = \frac{mg + F}{m}$
- D $a = g$

Your answer

[1]

9

15 The parallax angle for a star is 0.015 seconds of arc.

What is the distance in parsecs (pc) of the star from the Earth?

- A 67 pc
- B 133 pc
- C 220 pc
- D 2.1×10^{18} pc

Your answer

[1]

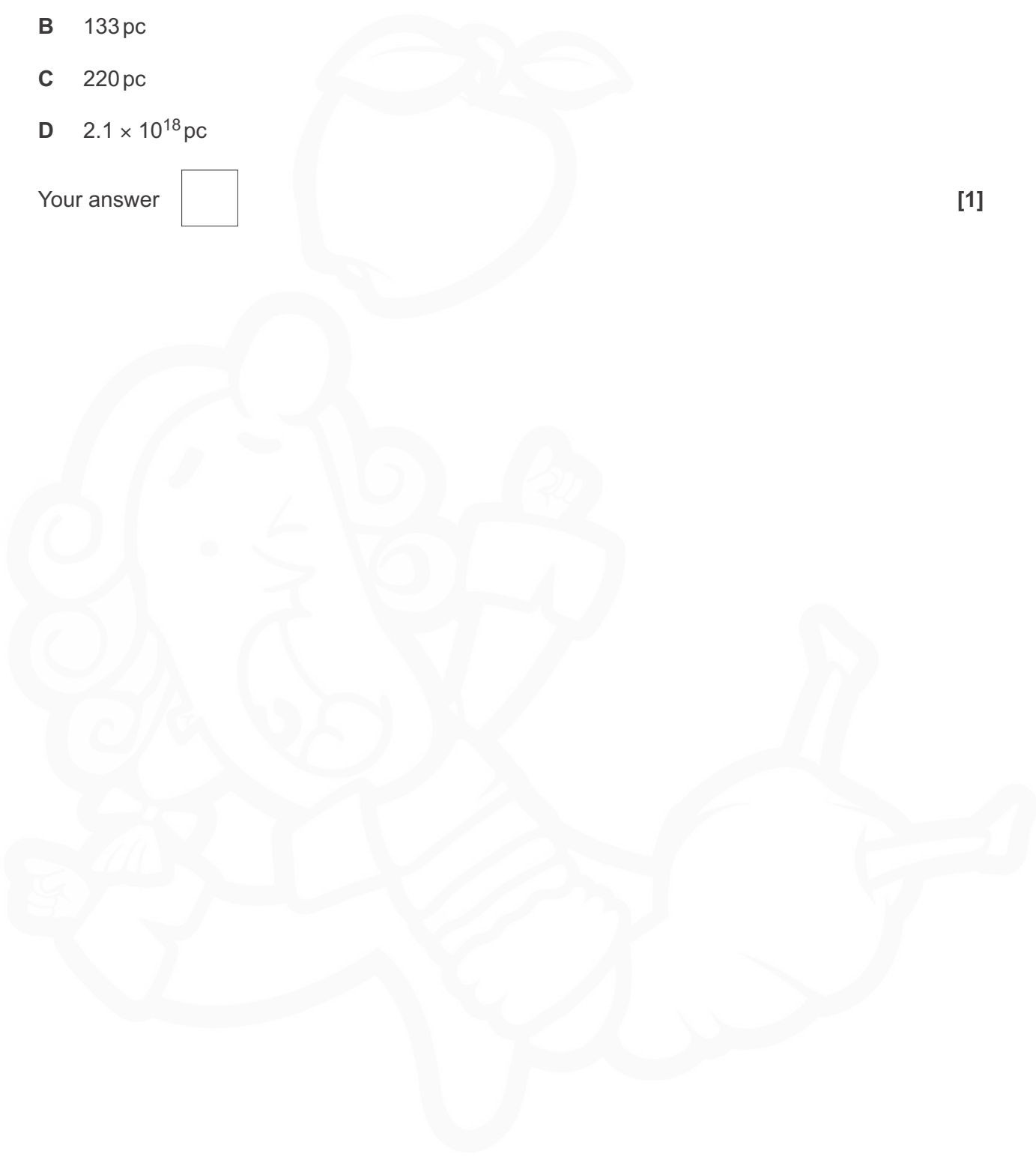

SECTION B

Answer **all** the questions.

16 A student wants to determine the value of the acceleration of freefall g .

(a) The diagram below shows part of the arrangement which the student used.

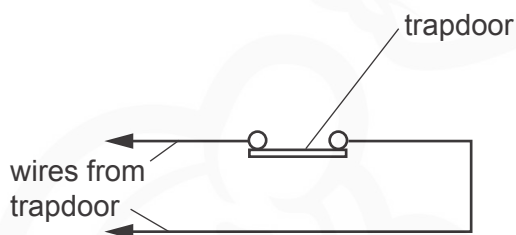
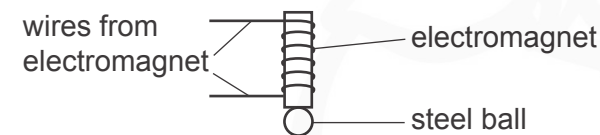

A steel ball is dropped from an electromagnet. The ball falls vertically. The ball hits a trapdoor and opens the trapdoor.

The ball travels a distance s from the bottom of the electromagnet to the trapdoor in a time t .

The student uses the equation $s = \frac{1}{2}gt^2$ to determine g .

(i) Show that the equation $s = \frac{1}{2}gt^2$ is homogeneous, with both sides of the equation having the same base units.

[2]

(ii) Describe how the student could use standard laboratory equipment to take accurate measurements of the distance s and the time t .

.....

.....

.....

.....

.....

.....

.....

.....

.....

.....

[4]

- (b) The trapdoor falls downwards when the ball hits it.
The ball collides **elastically** with the trapdoor with a speed of 4.4 ms^{-1} .

The graph of force acting on the ball against time is shown below.

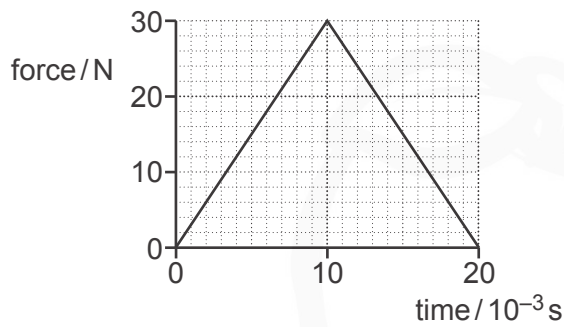

The mass of the ball is 0.050 kg .

- (i) Calculate the initial momentum p_1 of the ball just before it hits the trapdoor.

$$p_1 = \dots\dots\dots \text{ kg ms}^{-1} \text{ [1]}$$

- (ii) Use the graph to calculate the magnitude of the final momentum p_2 of the ball immediately after the collision.

$$p_2 = \dots\dots\dots \text{ kg ms}^{-1} \text{ [3]}$$

- (iii) The mass of the trapdoor is 100 g .

Calculate the final speed v of the trapdoor immediately after the collision.

$$v = \dots\dots\dots \text{ ms}^{-1} \text{ [2]}$$

17 (a) A metal strip has thickness t , as shown below.

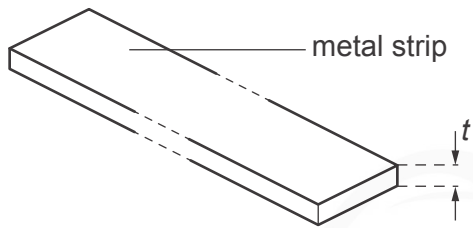

Five measurements of the thickness t at different positions along the length of the strip are shown below.

1.86 mm 1.88 mm 1.85 mm 1.89 mm 1.88 mm

Determine the percentage uncertainty in the thickness t .

percentage uncertainty = % [3]

(b)* A student wants to determine the Young modulus E of the metal of the strip in (a).

The student clamps the metal strip to the edge of a table using a G-clamp. A mass is **permanently** fixed to the end of the strip as shown.

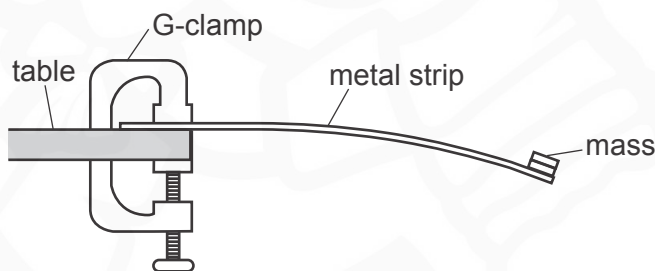

The mass oscillates freely when it is moved away from its equilibrium position and then released.

The Young modulus E of the metal can be determined using the equation $E = \frac{16\pi^2 mL^3}{wt^3 T^2}$, where m is the mass fixed to the end of the strip, L is the length of the strip from the end of the table to the centre of the mass, w is the width of the strip, t is the thickness of the strip, and T is the period of oscillations.

13

Describe how an experiment may be safely conducted, and how the data can be analysed to determine an accurate value for E . [6]

Dotted lines for writing the answer.

Additional answer space if required.

Dotted lines for writing the answer.

- 18 A 150W heater is used to heat 25g of ice in a sealed and well-insulated container. The initial temperature of the ice is -20°C .

The graph shows the variation of temperature θ with time t as the ice is heated.

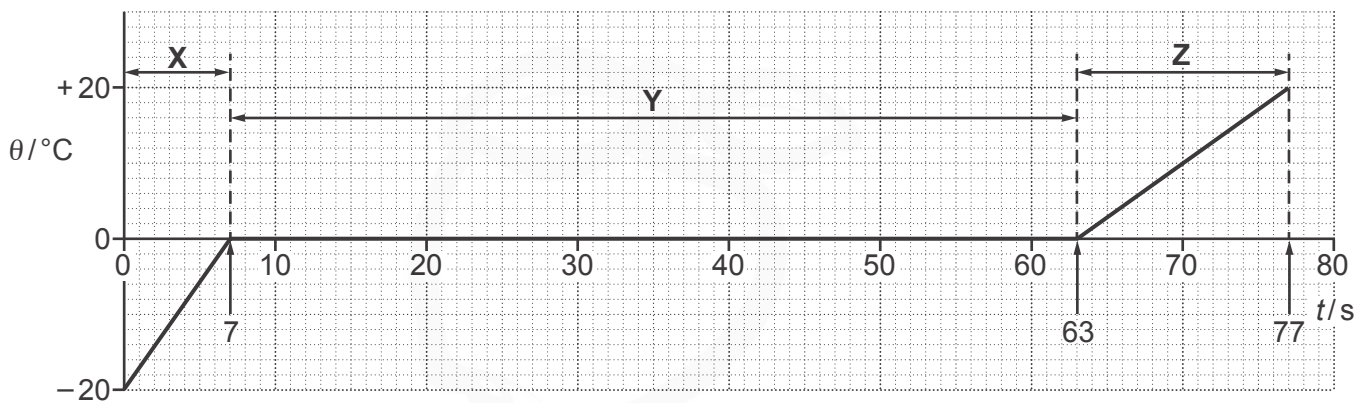

There are three distinct regions of the graph, **X**, **Y** and **Z**.

- (a) (i) Use the graph to determine the specific heat capacity c of the ice.

$$c = \dots\dots\dots \text{J kg}^{-1} \text{K}^{-1} \quad [3]$$

- (ii) Use the graph to determine the specific latent heat of fusion of ice L_f .

$$L_f = \dots\dots\dots \text{J kg}^{-1} \quad [2]$$

(iii) Use the graph to compare the specific heat capacities of ice and water. Explain your answer.

.....

.....

.....

..... [2]

(b) (i) Describe the motions of the molecules in region X and in region Z.

.....

.....

.....

..... [2]

(ii) The internal energy of the ice increases from $t = 0$ to $t = 77$ s.
Complete the table below using the following key for the physical quantities:

- K = kinetic energy of molecules
- P = potential energy of molecules.

Region	Physical quantity, or quantities, that increases as time increases	Physical quantity, or quantities, that remain constant as time increases
X		
Y		
Z		

[3]

(iii) State the temperature of the ice at which its molecules have zero kinetic energy.

..... [1]

- 19 A wheelie bin is tipped onto its wheels by applying two forces F and R .

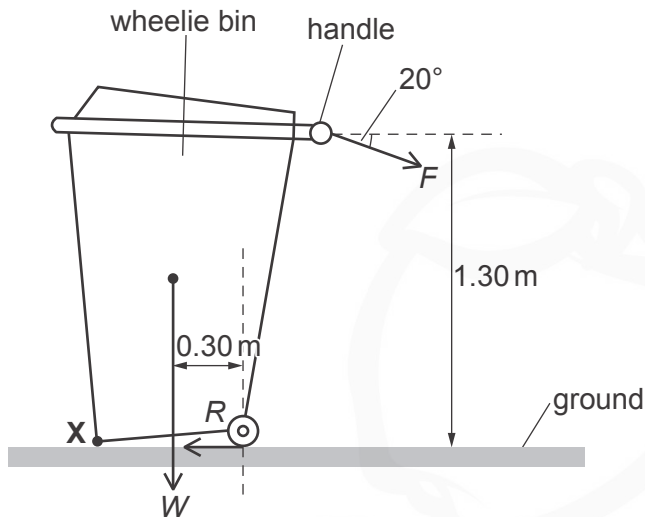

F is applied to the handle. F is to the right at an angle 20° below the horizontal.

The height of the handle above the ground is 1.30 m.

R is a horizontal force applied to the left to the wheels.

The total weight of the wheelie bin and its contents is W .

The perpendicular distance between the line of action of the weight and the bottom of the wheels is 0.30 m.

The wheelie bin and contents have a total mass of 40 kg.

- (a) State the **principle of moments**.

.....
 [1]

- (b) (i) Show that the magnitude of the minimum force F which lifts the front end of the wheelie bin (point X) off the ground is 96 N.

[3]

- (ii) Use your answer to (b)(i) to calculate the magnitude of the force R required to stop the wheelie bin from moving to the right.

$R = \dots\dots\dots$ N [2]

- (c) The wheelie bin is now placed on an adjustable slope. The wheels are now fixed so they cannot move.

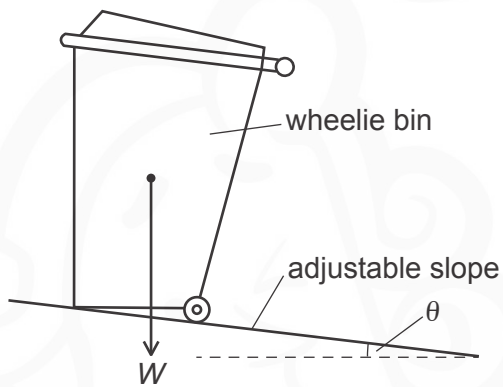

The angle θ made by the slope with the horizontal is steadily increased from zero.

Explain, without calculation, at what angle θ the wheelie bin starts to topple clockwise.

.....
 [1]

20 (a) The diagram below shows the Earth in space.



- (i) On the diagram above, draw a minimum of **four** gravitational field lines to map out the gravitational field pattern around the Earth. [1]
 - (ii) On the same diagram above, show **two** different points where the gravitational potential is the same. Label these points **X** and **Y**. [1]
- (b)* A satellite is in a circular geostationary orbit around the centre of the Earth. The satellite has both kinetic energy and gravitational potential energy.

The mass of the satellite is 2500 kg and the radius of its circular orbit is 4.22×10^7 m.
The mass of the Earth is 5.97×10^{24} kg.

- Describe some of the features of a geostationary orbit.
- Calculate the **total** energy of the satellite in its geostationary orbit. [6]

.....

.....

.....

.....

.....

.....

.....

.....

.....

.....

.....

.....

.....

.....

.....

.....

Additional answer space if required.

.....

.....

.....

.....

.....

.....

.....

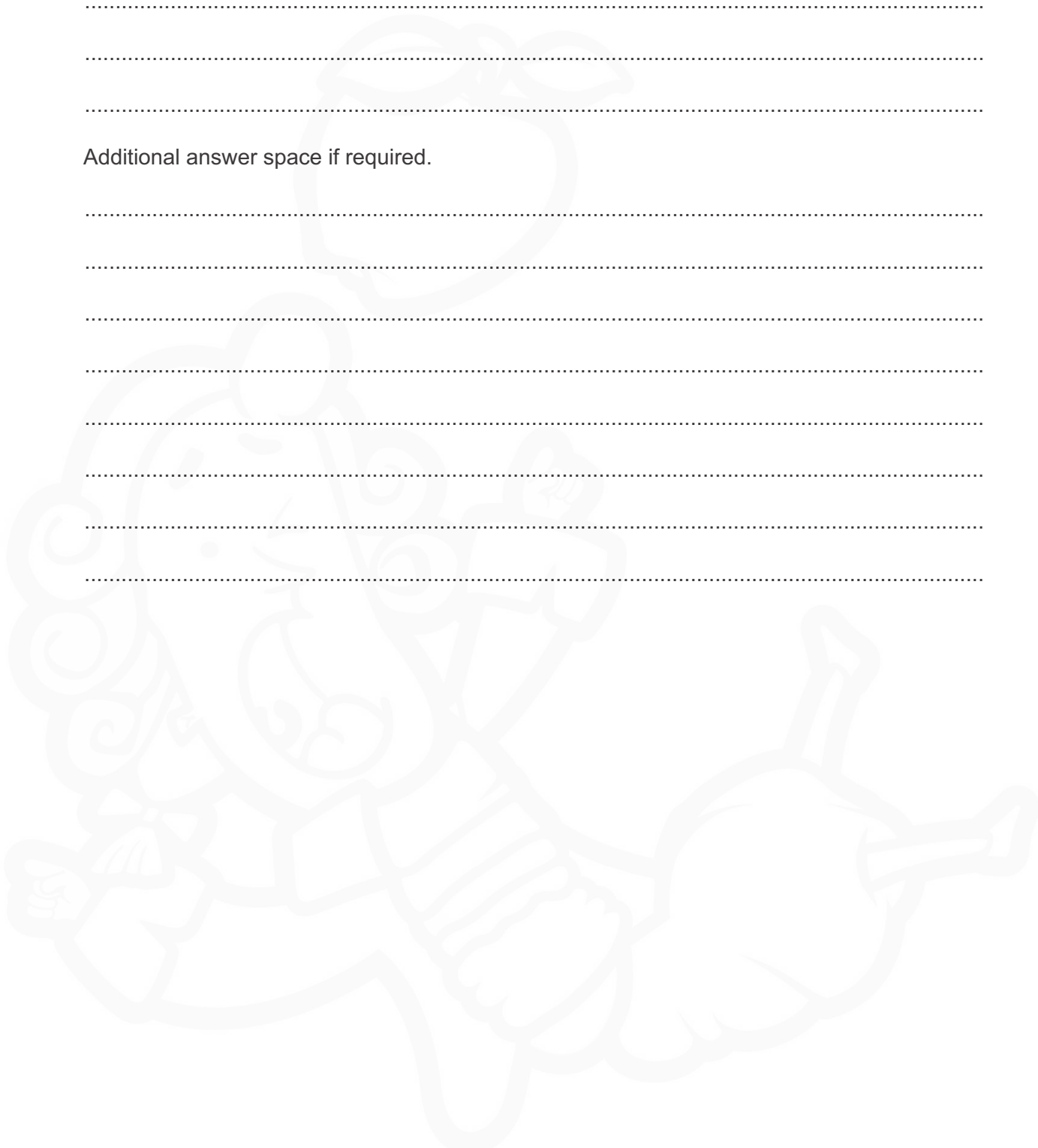

- 21 (a) One end of a spring is fixed to a support. A toy car, which is on a smooth horizontal track, is pushed against the free end of the spring. The spring compresses. The car is then released. The car accelerates to the right until the spring returns back to its original length.

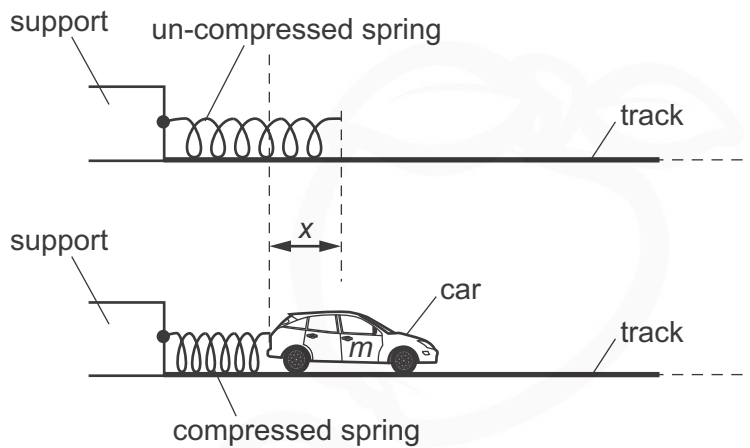

The car moves with **simple harmonic motion** as the spring returns to its original length. The acceleration of the car is given by the expression $a = -\left(\frac{k}{m}\right)x$, where m is the mass of the car, k is the force constant of the spring and x is the compression of the spring.

Use the data below to calculate the time t it takes for the spring to return to its original length after the car is released.

- mass of car $m = 80\text{ g}$
- force constant k of the spring $= 60\text{ N m}^{-1}$.

$t = \dots\dots\dots\text{ s [4]}$

- (b) The arrangement in (a) is used to propel the toy car along a smooth track.

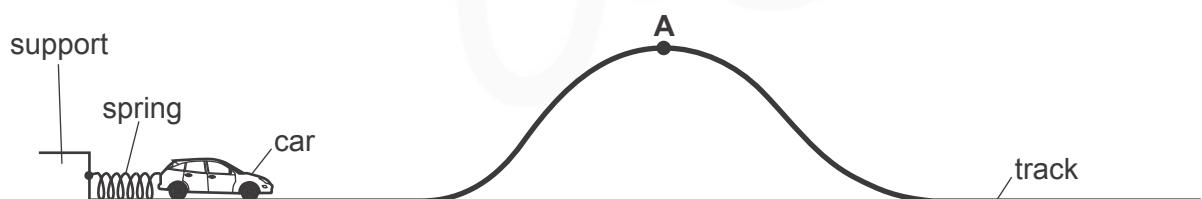

- (i) Point **A** is at the top of the track.
The launch speed of the car is now adjusted until the car just reaches **A** with zero speed.
The height of **A** is 0.20 m above the horizontal section of the track.

All the elastic potential energy of the spring is transferred to gravitational potential energy of the car.

Calculate the initial compression x of the spring.

$x = \dots\dots\dots$ m [3]

- (ii) At a specific speed, the car leaves point **A** horizontally and lands on the track at point **B**.
The horizontal distance between **A** and **B** is D .

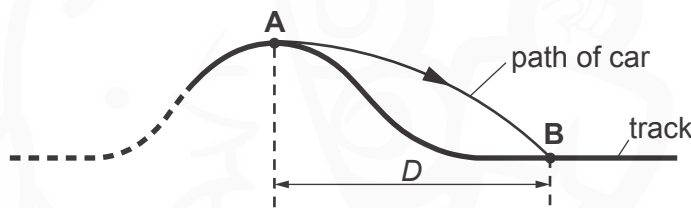

Air resistance has negligible effect on the motion of the car between **A** and **B**.

- 1 Explain how the time of flight between **A** and **B** depends on the speed of the car at **A**.

.....

 [2]

- 2 Explain how the distance D depends on the speed of the car at **A**.

.....

 [2]

22

- 22 (a) A particle-accelerator uses a ring of electromagnets to keep protons moving continuously in a circle.

The speed v of the protons depends on the frequency f of rotation of the protons in the circular orbit.

Fig. 22 shows data points plotted on a v against f grid.

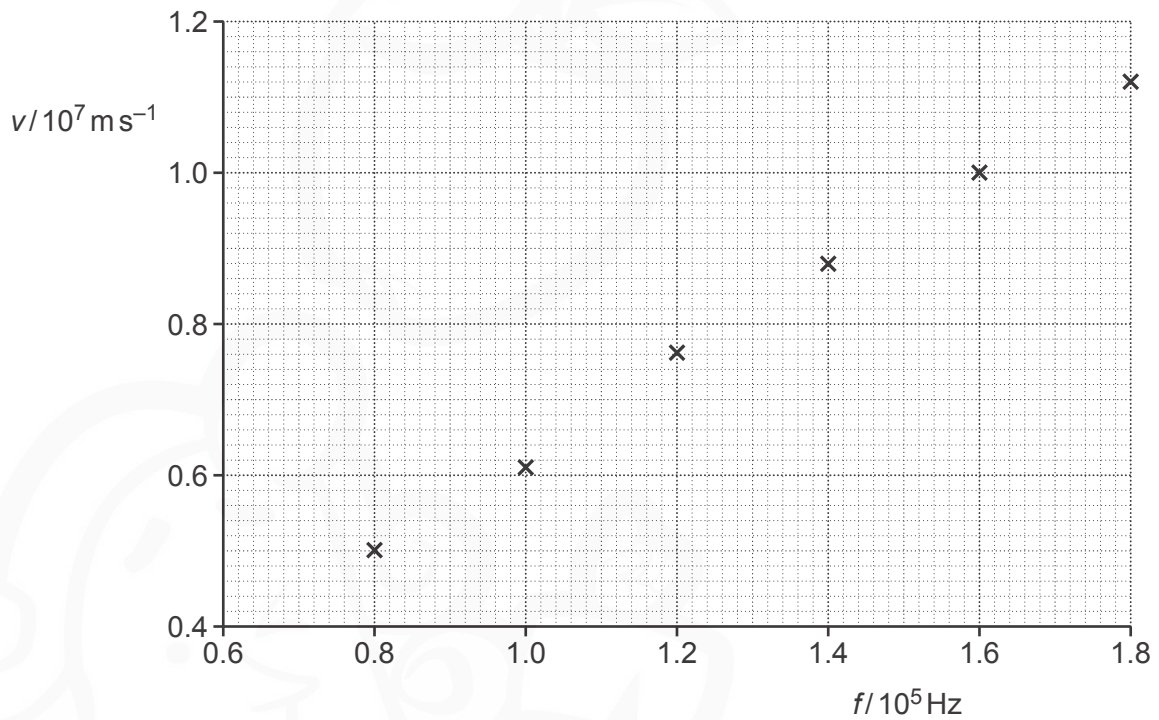

Fig. 22

- (i) Show that the gradient of the graph of v against f is equal to $2\pi r$, where r is the radius of the circular path of the protons.

[2]

- (ii) Show that r is about 10 m by determining the gradient of the line of best fit through the data points in **Fig. 22**.

[3]

- (iii) The maximum speed of the protons from this accelerator is $2.0 \times 10^7 \text{ m s}^{-1}$.

Calculate the maximum centripetal force F acting on a proton at this speed.

- mass of proton = $1.7 \times 10^{-27} \text{ kg}$.

$F = \dots\dots\dots \text{ N}$ [3]

- (b) A new particle-accelerator is now built for moving the protons in a circle of a radius 20 m.

The ring of electromagnets for this new accelerator provides the same **maximum** centripetal force as the accelerator in (a).

Calculate the maximum speed of the protons in this new accelerator.

maximum speed = $\dots\dots\dots \text{ m s}^{-1}$ [2]

24

23 Algol is a triple-star system, with stars Aa1, Aa2 and Aa3 orbiting each other. This triple-star is 90 light-years from the Earth.

(a) Here is some data on the star Aa1.

- radius = $(1.90 \pm 0.14) \times 10^9$ m
- mass = $(6.31 \pm 0.42) \times 10^{30}$ kg.

Calculate the gravitational field strength g at the surface of Aa1 to **3** significant figures. Include the absolute uncertainty in your answer. Assume that the other stars of the system exert negligible gravitational force on Aa1.

$g = \dots \pm \dots \text{ N kg}^{-1}$ [4]

(b) The table shows some data about the three stars of Algol.

Star	Luminosity of star / L_{\odot}	Surface temperature of star / K
Aa1	182	13 000
Aa2	6.92	4500
Aa3	10.0	7500

The luminosity of each star is in terms of the solar luminosity L_{\odot} .

(i) Define the **luminosity** of a star.

.....
..... [1]

(ii) Use Stefan's law to determine the ratio $\frac{\text{radius of star Aa2}}{\text{radius of star Aa3}}$.

ratio = [2]

- (iii) Use Wien's displacement law to explain which star would have the **longest** wavelength at the peak intensity of the emitted electromagnetic radiation.

.....
.....
..... [2]

- (iv) Suggest how an astronomer using just an optical telescope can deduce that the three stars of Algol have different surface temperatures.

.....
..... [1]

- (v) The light from each star passing through a diffraction grating shows an absorption line spectrum.

Explain how a specific absorption line is produced in this type of spectrum in terms of **photons** and **electrons**.

.....
.....
.....
.....
.....
.....
..... [3]

- (c) The Aa1 star could evolve into a black hole.

State **two** ways in which the black hole would differ from the Aa1 star.

1.
.....
2.
.....
..... [2]

END OF QUESTION PAPER

ADDITIONAL ANSWER SPACE

If additional space is required, you should use the following lined page(s). The question number(s) must be clearly shown in the margin(s).

The page contains 20 horizontal dotted lines for writing, with a vertical margin line on the left side. A faint watermark of a cartoon character is visible in the background.

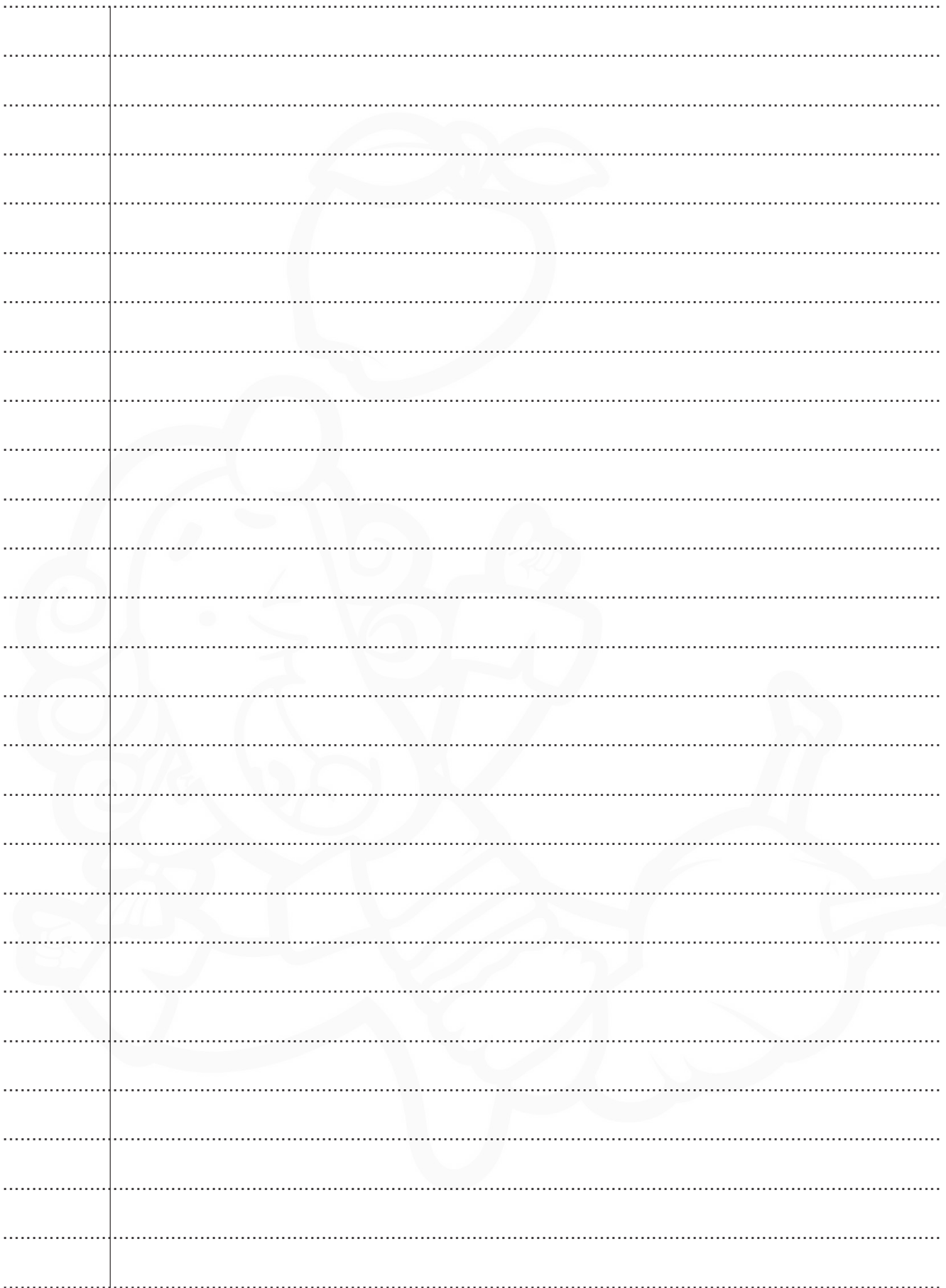

A large area of the page is filled with horizontal dotted lines, providing a space for students to write their answers. A solid vertical line runs down the left side of this area, creating a margin.

OCR
Oxford Cambridge and RSA

Copyright Information

OCR is committed to seeking permission to reproduce all third-party content that it uses in its assessment materials. OCR has attempted to identify and contact all copyright holders whose work is used in this paper. To avoid the issue of disclosure of answer-related information to candidates, all copyright acknowledgements are reproduced in the OCR Copyright Acknowledgements Booklet. This is produced for each series of examinations and is freely available to download from our public website (www.ocr.org.uk) after the live examination series. If OCR has unwittingly failed to correctly acknowledge or clear any third-party content in this assessment material, OCR will be happy to correct its mistake at the earliest possible opportunity.

For queries or further information please contact The OCR Copyright Team, The Triangle Building, Shaftesbury Road, Cambridge CB2 8EA.

OCR is part of the Cambridge Assessment Group; Cambridge Assessment is the brand name of University of Cambridge Local Examinations Syndicate (UCLES), which is itself a department of the University of Cambridge.