



# Cambridge IGCSE™

CANDIDATE  
NAME

--

CENTRE  
NUMBER

--	--	--	--	--

CANDIDATE  
NUMBER

--	--	--	--



## PHYSICS

0625/62

Paper 6 Alternative to Practical

February/March 2021

1 hour

You must answer on the question paper.

No additional materials are needed.

### INSTRUCTIONS

- Answer **all** questions.
- Use a black or dark blue pen. You may use an HB pencil for any diagrams or graphs.
- Write your name, centre number and candidate number in the boxes at the top of the page.
- Write your answer to each question in the space provided.
- Do **not** use an erasable pen or correction fluid.
- Do **not** write on any bar codes.
- You may use a calculator.
- You should show all your working and use appropriate units.

### INFORMATION

- The total mark for this paper is 40.
- The number of marks for each question or part question is shown in brackets [ ].

This document has **16** pages. Any blank pages are indicated.

1 A student investigates the motion of an oscillating metre rule.

He uses the apparatus shown in Fig. 1.1.

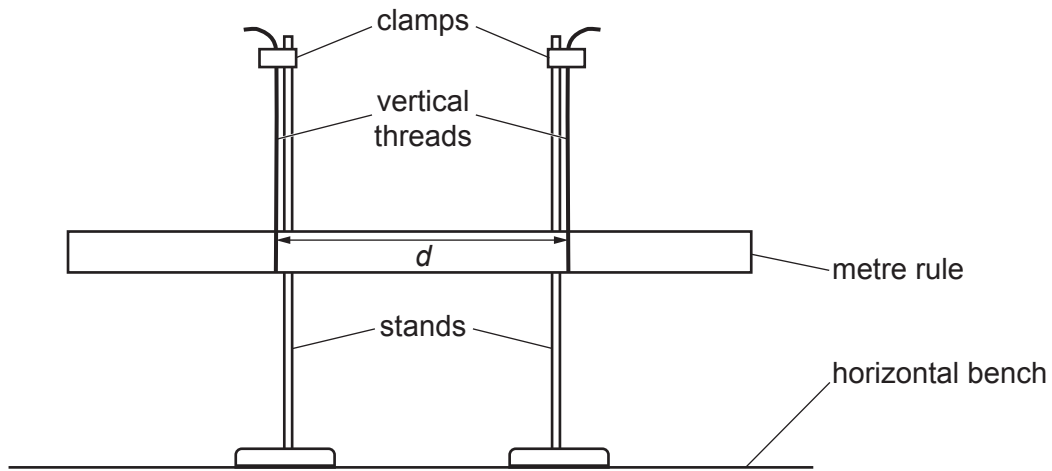

Fig. 1.1

(a) The student ensures that the metre rule is horizontal.

Briefly describe how to check that the metre rule is horizontal. You may draw a diagram or draw on Fig. 1.1 if it helps to explain your answer.

.....

.....

..... [1]

- (b) The student moves the stands so that the vertical threads are at the marks on the metre rule shown in Fig. 1.2.

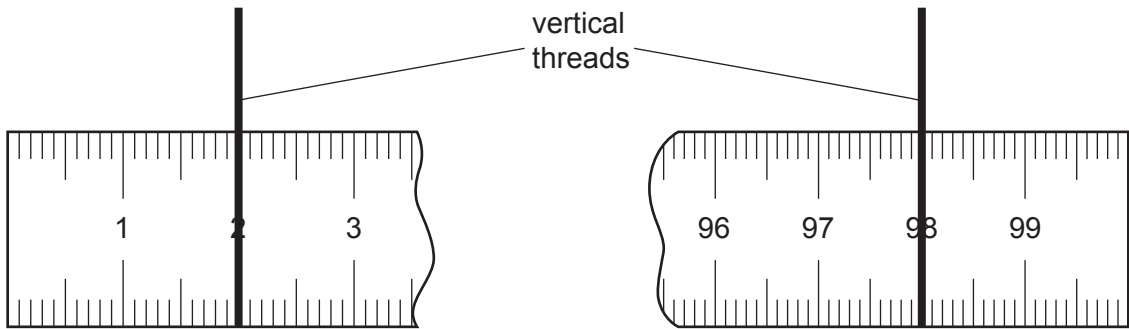

Fig. 1.2

Calculate the distance  $d$  between the threads.

$d = \dots\dots\dots$  cm [1]

- (c) He twists the metre rule a small amount, as shown in Fig. 1.3, and then lets it go so that it oscillates in a rotating motion.

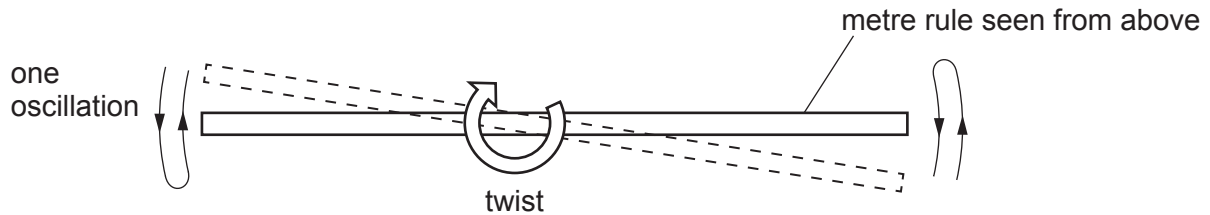

Fig. 1.3

He measures the time  $t$  for 5 complete oscillations of the metre rule.

$t = \dots\dots\dots 3.63 \dots\dots\dots$  s

Suggest why it is useful to take a trial reading for this experiment.

.....  
 ..... [1]

- (d) The student carries out the same procedure for  $d$  values of 20.0 cm, 30.0 cm, 40.0 cm, 50.0 cm and 60.0 cm. His readings are shown in Table 1.1.

**Table 1.1**

$d/\text{cm}$	$t/\text{s}$	$\frac{1}{T}/\frac{1}{\text{s}}$
20.0	17.85	
30.0	11.36	0.44
40.0	8.77	0.57
50.0	6.93	0.72
60.0	5.68	0.88

For distance  $d = 20.0$  cm, calculate and record in Table 1.1, the value of  $\frac{1}{T}$  where  $T$  is the time for 1 oscillation of the metre rule.

Use the value of time  $t$  from Table 1.1 and the equation  $\frac{1}{T} = \frac{5}{t}$ .

[1]

- (e) Plot a graph of distance  $d/\text{cm}$  ( $y$ -axis) against  $\frac{1}{T}/\frac{1}{\text{s}}$  ( $x$ -axis).

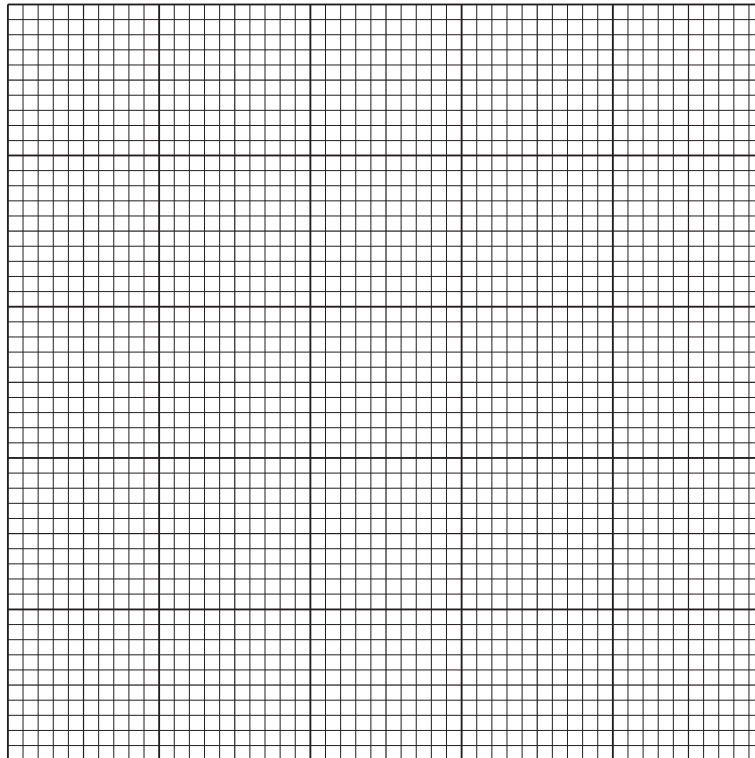

[4]

- (f) Determine the gradient  $G$  of the graph. Show clearly on the graph how you obtained the necessary information.

$G = \dots\dots\dots$  [1]

(g) (i) Explain why it is more accurate to measure the time for 5 oscillations rather than for 1 oscillation.

.....  
.....  
..... [1]

(ii) Describe how the experiment could be improved to make the readings more reliable.

.....  
.....  
..... [1]

[Total: 11]

- 2 Students investigate the cooling of hot water in two different cups.

They use the apparatus shown in Fig. 2.1.

Cup A is made from thin plastic. The top of cup A has an inside diameter of 7 cm. Cup B is made from expanded polystyrene. The top of cup B has an inside diameter of 8 cm.

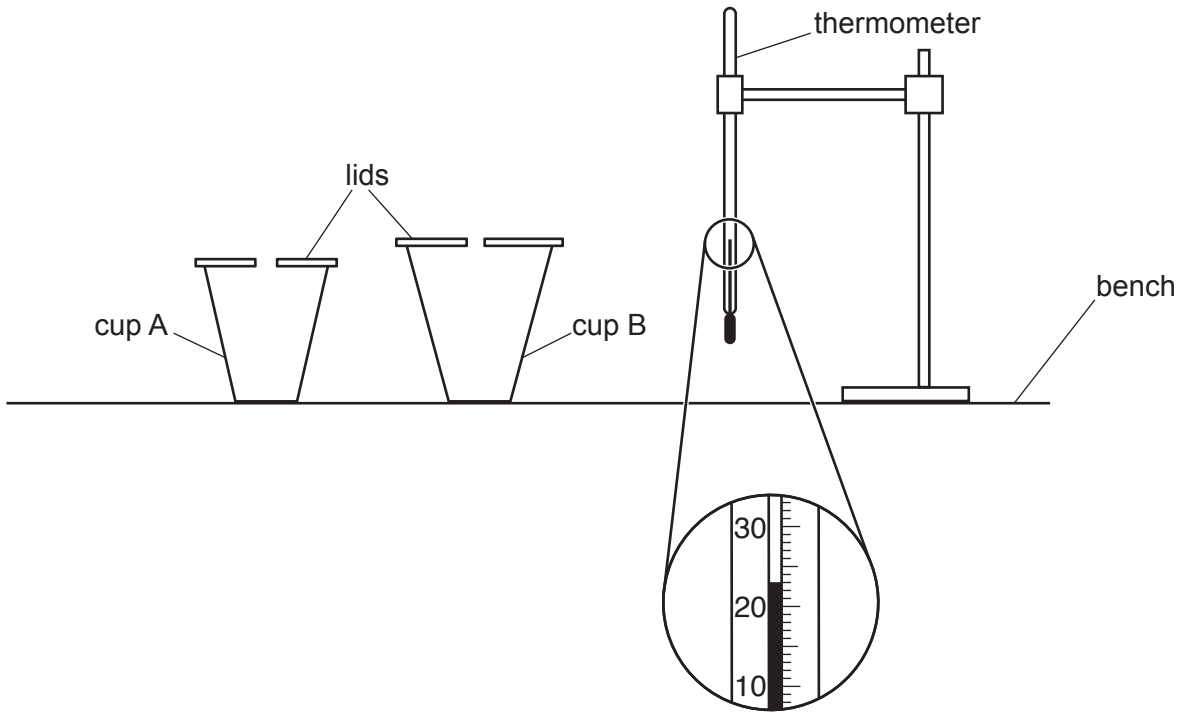

Fig. 2.1

- (a) (i) Record the room temperature  $\theta_R$  shown on the thermometer in Fig. 2.1.

$\theta_R = \dots\dots\dots$  [1]

- (ii) Describe **one** precaution that you would take to ensure that temperature readings in the experiment are as accurate as possible.

.....  
 ..... [1]

- (b) A volume of  $100\text{cm}^3$  of hot water is poured into each cup and the initial temperature  $\theta$  is recorded in Table 2.1.

The temperature of the water in each cup is recorded every 30s. The values are shown in Table 2.1.

**Table 2.1**

	cup A	cup B
$t/$	$\theta/$	$\theta/$
0	87.5	88.0
30	84.5	86.0
60	82.0	84.5
90	80.5	83.0
120	79.0	82.0
150	78.0	81.0
180	77.0	80.5

Complete the headings in Table 2.1.

[1]

- (c) Write a conclusion stating which cup, A or B, is the more effective in reducing the cooling rate of the hot water in this experiment.

Justify your answer by reference to the results.

.....

.....

.....

..... [2]

- (d) (i) Calculate  $x_A$ , the average cooling rate for cup A over the whole experiment. Use the readings for cup A from Table 2.1 and the equation

$$x_A = \frac{\theta_0 - \theta_{180}}{T}$$

where  $T = 180\text{s}$  and  $\theta_0$  and  $\theta_{180}$  are the temperatures at time  $t = 0$  and at time  $t = 180\text{s}$ . Include the unit for the cooling rate.

$x_A = \dots\dots\dots$  [2]

(ii) Suggest an additional experiment to show how the lid affects the cooling rate of cup A.

Explain how to use the additional results to show the effect.

additional experiment .....

.....

explanation .....

.....

.....

[2]

(e) A student wishes to compare the effect of the materials of the cups on cooling rates. Suggest **two** variables that she should control to make this test fair.

1. ....

.....

2. ....

.....

[2]

[Total: 11]



- 3 A student investigates a resistor and a lamp connected in series. She uses the circuit shown in Fig. 3.1.

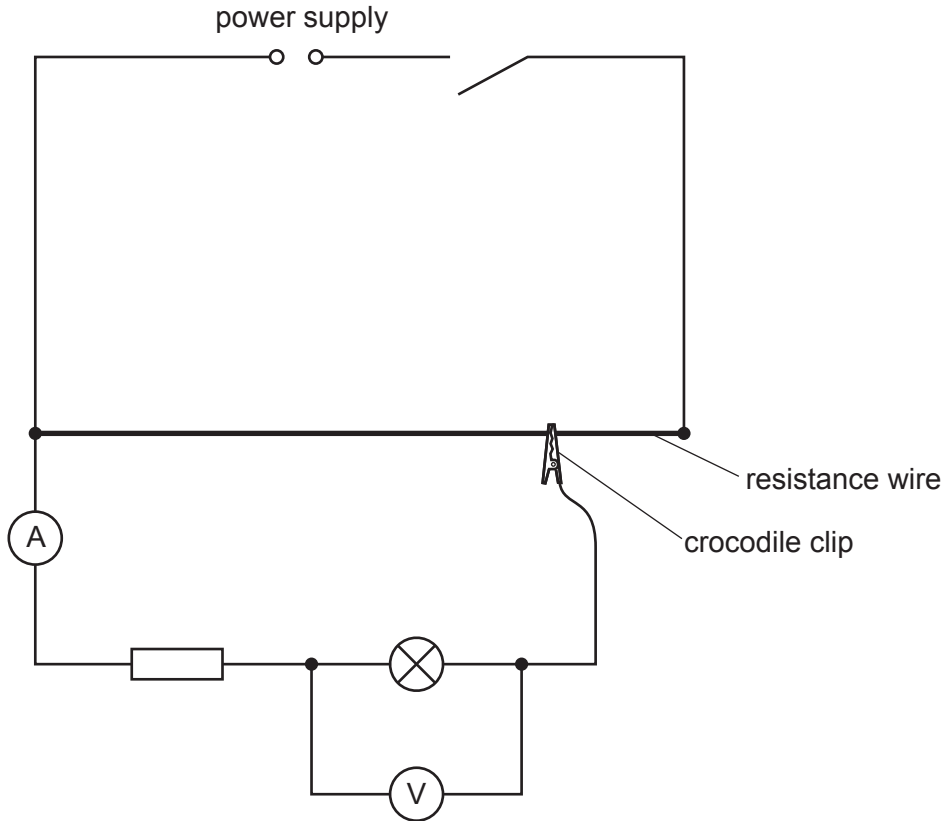
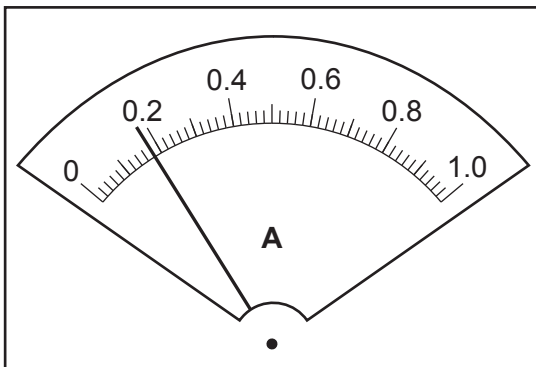

**Fig. 3.1**

- (a) The student moves the crocodile clip on the resistance wire so that the value of the potential difference  $V_L$  across the lamp is 2.0V.

She measures the current  $I$  for the lamp and resistor in series.

She then connects the voltmeter to measure the potential difference  $V_R$  across the resistor.



**Fig. 3.2**

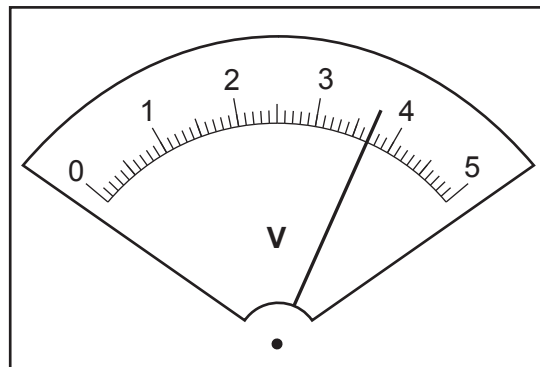

**Fig. 3.3**

Read, and record in Table 3.1, the values of  $I$  and  $V_R$  shown on the meters in Fig. 3.2 and Fig. 3.3.

[2]

- (b) The student repeats the steps in (a) for values of  $V_L = 1.0\text{V}$  and  $V_L = 0.5\text{V}$ . Her readings are shown in Table 3.1.

**Table 3.1**

$V_L/\text{V}$	$I/\text{A}$	$V_R/\text{V}$	$R_L/\Omega$	$R_R/\Omega$
2.0				
1.0	0.15	3.0		
0.5	0.12	2.4		

Calculate, and record in Table 3.1, the resistance of the lamp  $R_L$  for each value of  $V_L$ .

Use the values of  $V_L$  and  $I$  from Table 3.1 and the equation  $R_L = \frac{V_L}{I}$ .

Calculate, and record in Table 3.1, the resistance of the resistor  $R_R$  for each value of  $V_L$ .

Use the values of  $V_R$  and  $I$  from Table 3.1 and the equation  $R_R = \frac{V_R}{I}$ .

[2]

- (c) (i) Describe the pattern of any change in the value of  $R_L$  as  $V_L$  decreases.

.....  
 ..... [1]

- (ii) A student suggests that  $R_R$  should be constant.

State whether your results support this suggestion.  
 Justify your statement by reference to values from Table 3.1.

statement .....

.....

justification .....

.....

..... [2]

- (d) A student wishes to determine the resistance of the lamp  $R_L$  when the potential difference across the lamp  $V_L = 0.0V$ .

Describe how the experiment can be extended to do this with the help of a suitable graph.

.....

.....

.....

..... [2]

- (e) It is possible to use a variable resistor instead of a resistance wire to change the potential difference across the lamp.

Complete the circuit in Fig. 3.4 to show:

- a variable resistor used for this purpose
- the voltmeter connected to measure the potential difference across the resistor

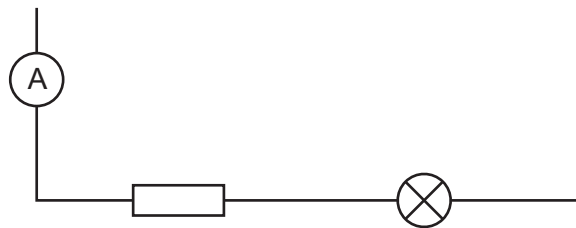
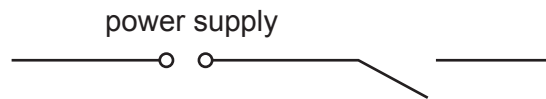

Fig. 3.4

[2]

[Total: 11]

- 4 A student investigates the motion of a ball rolling down a slope.

Plan an experiment which enables him to investigate how **one** factor affects the average speed of the ball.

Average speed can be calculated using the equation:

$$\text{average speed} = \frac{\text{distance travelled}}{\text{time taken}}$$

The apparatus available includes:

balls of various sizes and materials  
a board which can act as a slope  
blocks to support one end of the board.

In your plan, you should:

- state a factor which can be measured
- list any additional apparatus needed
- explain briefly how to carry out the experiment including exactly which measurements are to be taken
- state the key variables to be kept constant
- draw a table, or tables, with column headings, to show how to display the readings (you are **not** required to enter any readings in the table)
- explain how to use the readings to reach a conclusion.

You may draw a diagram if it helps to explain your plan.







**BLANK PAGE**

---

Permission to reproduce items where third-party owned material protected by copyright is included has been sought and cleared where possible. Every reasonable effort has been made by the publisher (UCLES) to trace copyright holders, but if any items requiring clearance have unwittingly been included, the publisher will be pleased to make amends at the earliest possible opportunity.

To avoid the issue of disclosure of answer-related information to candidates, all copyright acknowledgements are reproduced online in the Cambridge Assessment International Education Copyright Acknowledgements Booklet. This is produced for each series of examinations and is freely available to download at [www.cambridgeinternational.org](http://www.cambridgeinternational.org) after the live examination series.

Cambridge Assessment International Education is part of the Cambridge Assessment Group. Cambridge Assessment is the brand name of the University of Cambridge Local Examinations Syndicate (UCLES), which itself is a department of the University of Cambridge.