

Cambridge  
**IGCSE**

**Cambridge Assessment International Education**  
Cambridge International General Certificate of Secondary Education

CANDIDATE  
NAME

CENTRE  
NUMBER

--	--	--	--	--	--

CANDIDATE  
NUMBER

--	--	--	--	--



**PHYSICS**

Paper 3 Theory (Core)

**0625/33**

**May/June 2019**

**1 hour 15 minutes**

Candidates answer on the Question Paper.

No Additional Materials are required.

**READ THESE INSTRUCTIONS FIRST**

Write your centre number, candidate number and name on all the work you hand in.

Write in dark blue or black pen.

You may use an HB pencil for any diagrams or graphs.

Do not use staples, paper clips, glue or correction fluid.

**DO NOT WRITE IN ANY BARCODES.**

Answer **all** questions.

Electronic calculators may be used.

You may lose marks if you do not show your working or if you do not use appropriate units.

Take the weight of 1.0 kg to be 10 N (acceleration of free fall = 10 m/s<sup>2</sup>).

At the end of the examination, fasten all your work securely together.

The number of marks is given in brackets [ ] at the end of each question or part question.

This syllabus is regulated for use in England, Wales and Northern Ireland as a Cambridge International Level 1/Level 2 Certificate.

This document consists of **16** printed pages.

1 Fig. 1.1 shows three metal blocks. Each block has the same mass.

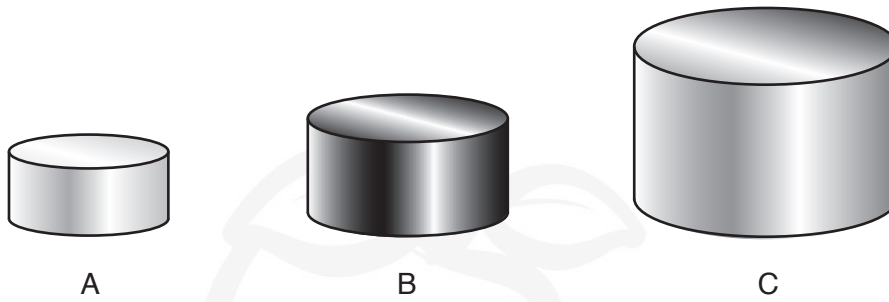

Fig. 1.1

The volumes of the blocks are different.

Each block is made of a different metal. The table gives the density of each metal.

name of metal	density (g/cm <sup>3</sup> )
aluminium	2.83
iron	6.95
lead	11.3

(a) Use the data from the table to identify the metal used to make each block.

A .....

B .....

C .....

[1]

(b) Another metal block is made of brass. Its mass is 200 g.

The density of brass is 8.4 g/cm<sup>3</sup>.

Calculate the volume of the brass block.

volume = ..... cm<sup>3</sup> [3]

(c) Describe a method for determining the volume of a small, dense, irregularly-shaped object.

You may draw a labelled diagram.

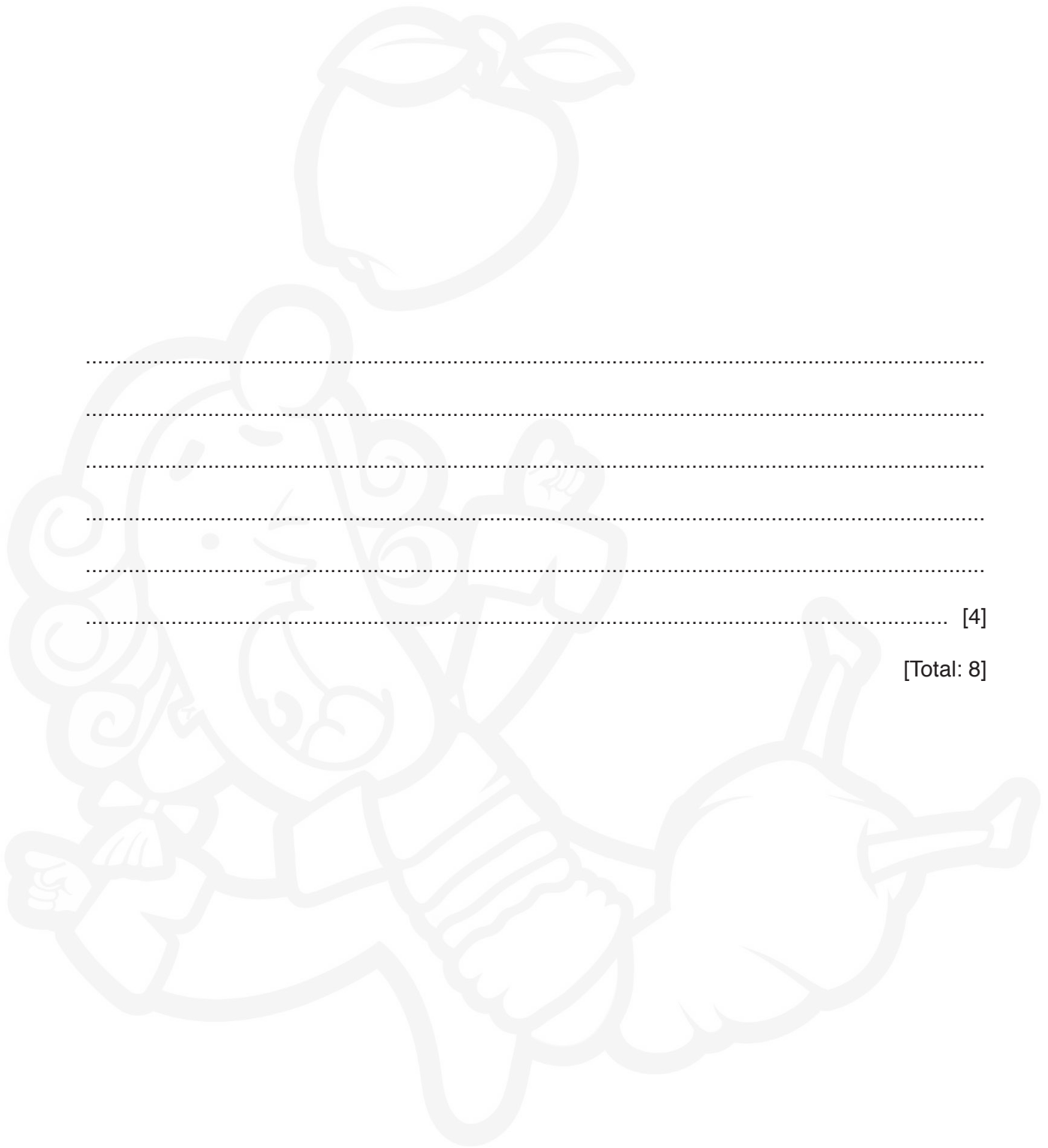

[4]

[Total: 8]

- 2 Fig. 2.1 shows a distance-time graph for a man walking from home to a café. At the café the man stops for a drink. On the return journey from the café, the man stops to rest.

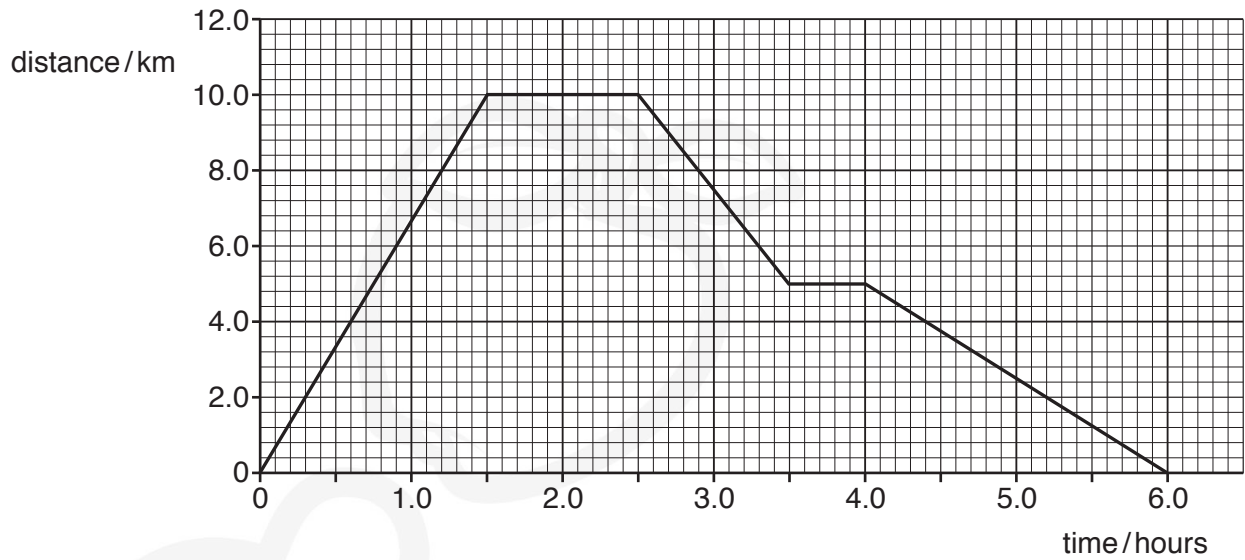

Fig. 2.1

(a) Using Fig. 2.1, determine

- (i) the distance from the man's home to the café.

distance = ..... km [1]

- (ii) the time taken to walk to the café.

time = ..... hours [1]

- (iii) the speed, in km/hour, of the man as he walks to the café.

speed = ..... km/hour [3]

(b) On the return journey from the café, the man stopped to rest.

(i) The man left home at 13:00.

Determine the time when the man began his rest.

time when rest began ..... [1]

(ii) For how long did the man rest on the return journey? State the time in minutes.

time = ..... minutes [1]

(iii) Describe, in words, how the graph in Fig. 2.1 shows that the man travelled at a slower speed on the return journey after resting.

.....  
..... [1]

[Total: 8]

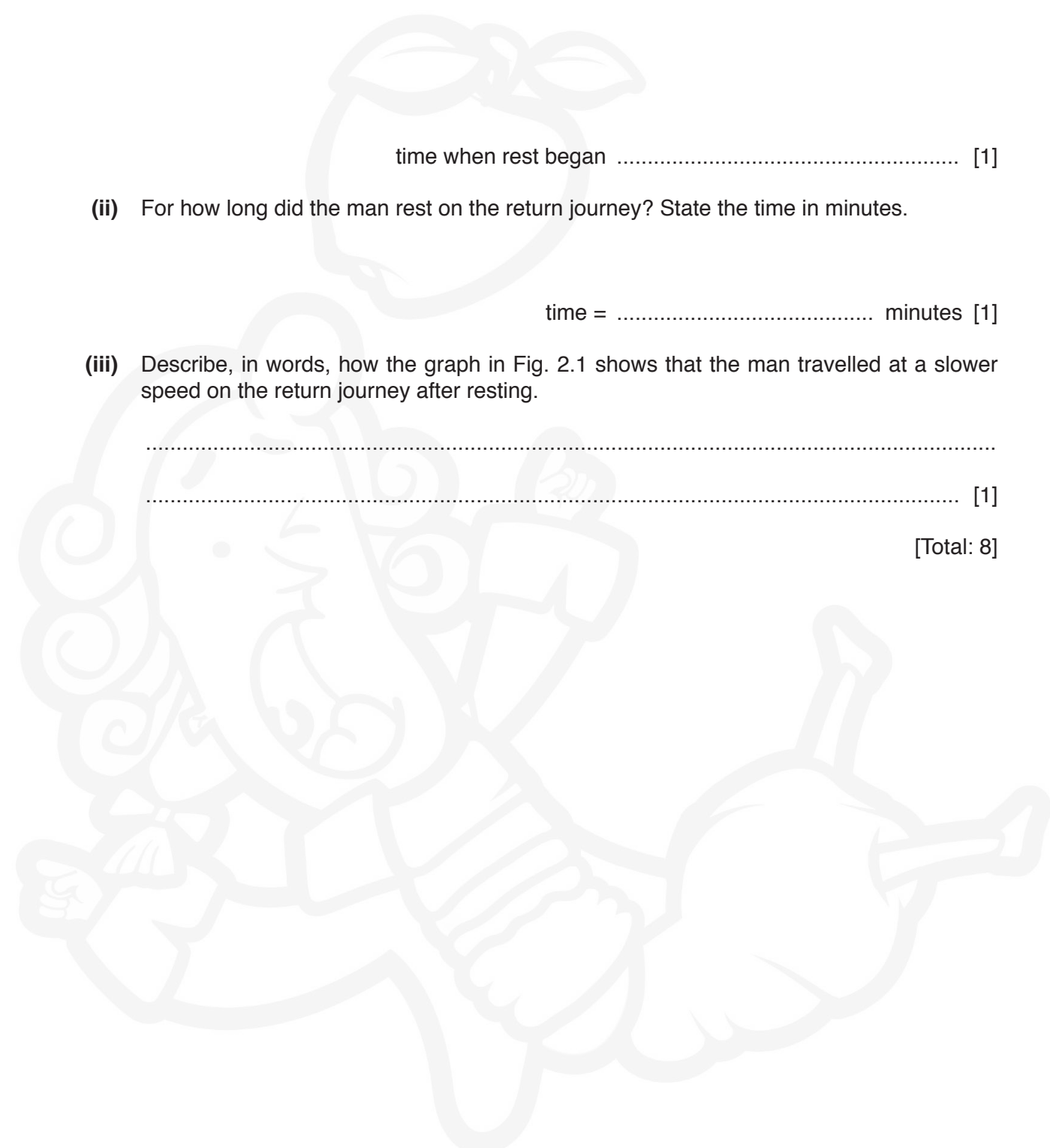

3 Fig. 3.1 shows a wheelbarrow and Fig. 3.2 shows the dimensions of its wheel.

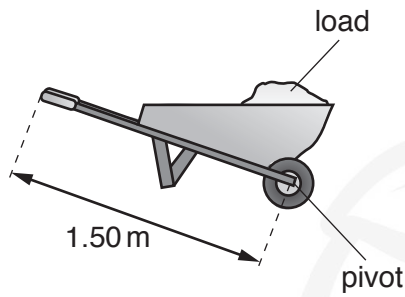

Fig. 3.1

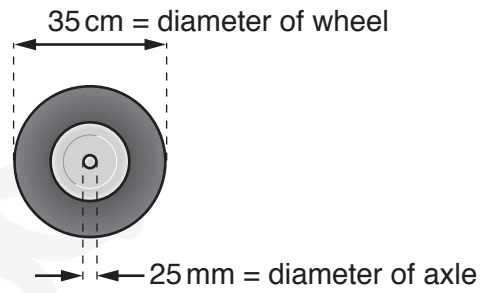

Fig. 3.2

(a) Complete the table to show the diameter of the wheel and axle in metres.

	measurement	measurement in metres
diameter of wheel	35 cm	
diameter of axle	25 mm	

[2]

(b) The mass of the wheelbarrow is 20 kg. The mass of the load in the wheelbarrow is 30 kg. Calculate the total weight of the wheelbarrow and its load.

weight of wheelbarrow and load = ..... N [3]

(c) A man lifts the handle of the wheelbarrow. He applies a force of 140 N, as shown in Fig. 3.3.

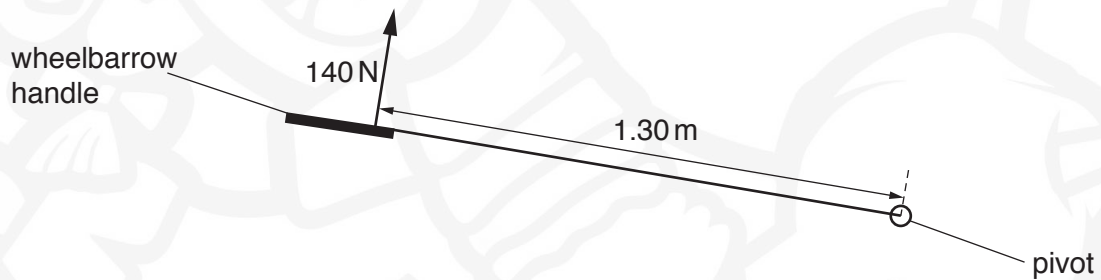

Fig. 3.3

Calculate the moment of the force about the pivot. Include the unit.

moment = ..... [4]

[Total: 9]

4 Fig. 4.1 shows a flat-top cone and a sphere, resting on a table.

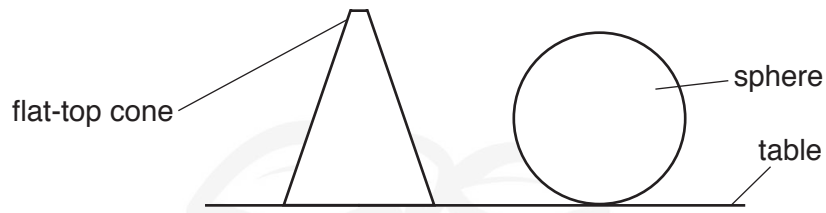

Fig. 4.1

- (a) On Fig. 4.1, mark a cross on each object to show the position of the centre of mass of each object. [2]
- (b) The cone is inverted and balanced on its top, as shown in Fig. 4.2.



Fig. 4.2

Explain why the flat-top cone is less stable when it is inverted.

.....

.....

.....

.....

..... [3]

[Total: 5]

5 Fig. 5.1 represents part of a roller coaster track.

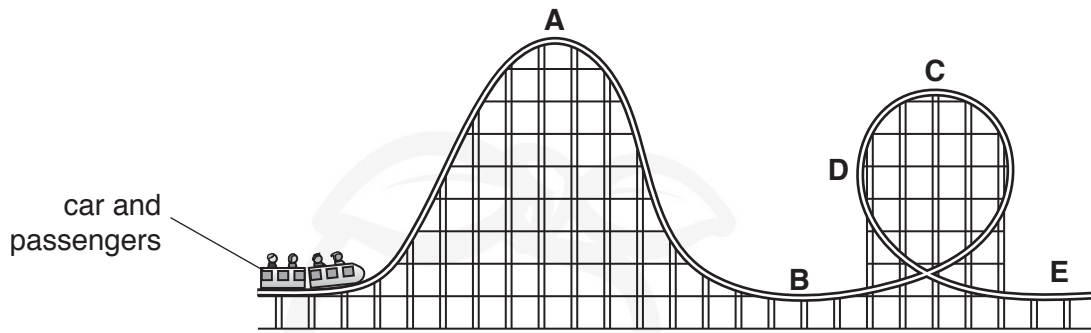

Fig. 5.1

(a) The car is lifted to point **A** and then released. It continues along the track.

Complete the sentences about the energy of the car using letters from Fig. 5.1.

The car has maximum gravitational potential energy at point .....

The car has maximum kinetic energy at point .....

[2]

(b) (i) State the principle of conservation of energy.

.....  
..... [2]

(ii) A machine lifts the car to point **A**. The machine is **not** 100% efficient.

Suggest why the machine is not 100% efficient. Use your ideas about energy.

.....  
..... [1]

[Total: 5]



6 Fig. 6.1 shows a metal pan containing water being heated by an electrical heater.



Fig. 6.1

(a) Complete the sentences to describe how thermal energy is transferred.

- (i) Thermal energy is transferred from the electrical heater to the bottom of the pan by ..... [1]
- (ii) Thermal energy is transferred through the bottom of the metal pan by ..... [1]
- (iii) Thermal energy is transferred throughout the water by ..... [1]

(b) A student carries out an experiment to determine which surface is the better emitter of thermal energy. She uses two similar metal containers. One of the containers has a dull black surface. The other has a shiny white surface. Fig. 6.2 shows the metal containers on a bench.

(i) Suggest a procedure for her experiment. You may add to Fig. 6.2 to assist with your explanation.

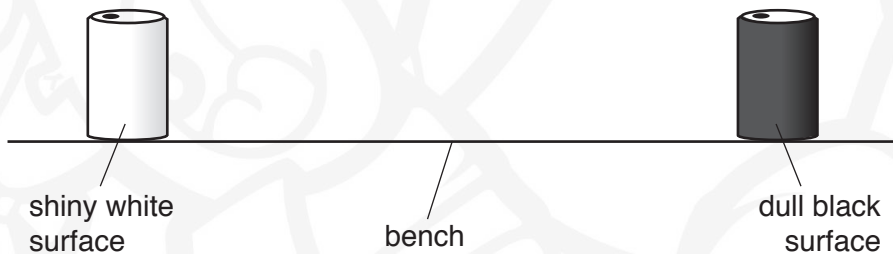

Fig. 6.2

.....  
 .....  
 .....  
 ..... [3]

(ii) Predict the result of the experiment described in (b)(i).

.....  
 ..... [1]

[Total: 7]

**[Turn over**

7 Fig. 7.1 shows a ray of red light being reflected at the flat surface of a glass block.

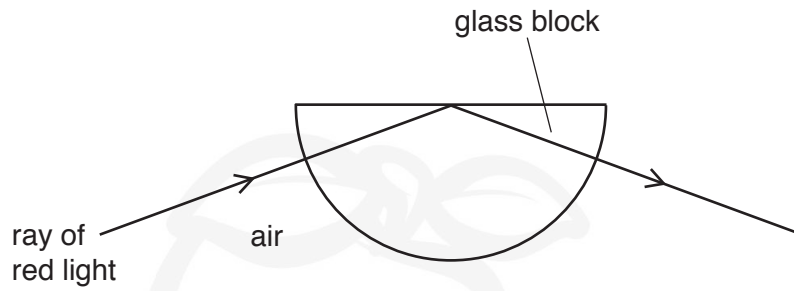

Fig. 7.1

(a) Explain why the ray of red light is totally internally reflected by the surface of the glass block.

.....  
..... [1]

(b) A ray of white light passes through a prism and produces a spectrum of colours on a screen, as shown in Fig. 7.2.

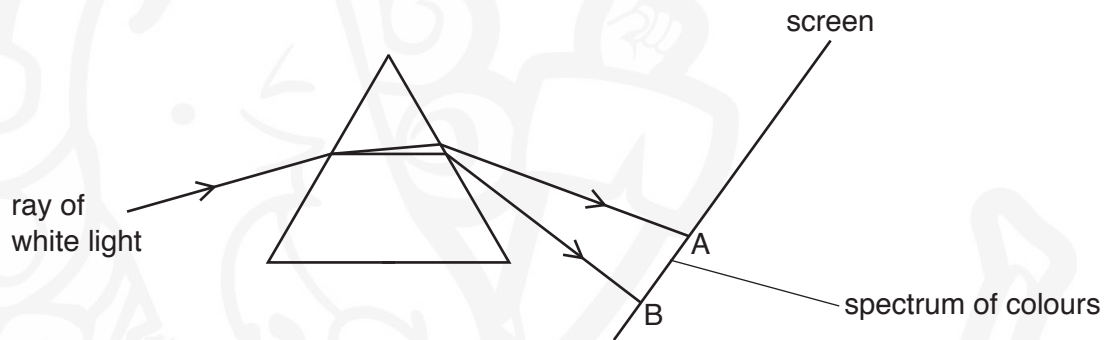

Fig. 7.2

(i) State the name of the process of separating white light into a spectrum.

..... [1]

(ii) Write the names of the seven colours that appear on the screen between A and B.

colour at A .....

.....

.....

.....

.....

.....

colour at B .....

[1]

(c) Visible light is one part of the electromagnetic spectrum.

State the name of **one** other part of the electromagnetic spectrum and describe a use of this type of radiation.

name of radiation .....

use of radiation .....

[2]

[Total: 5]

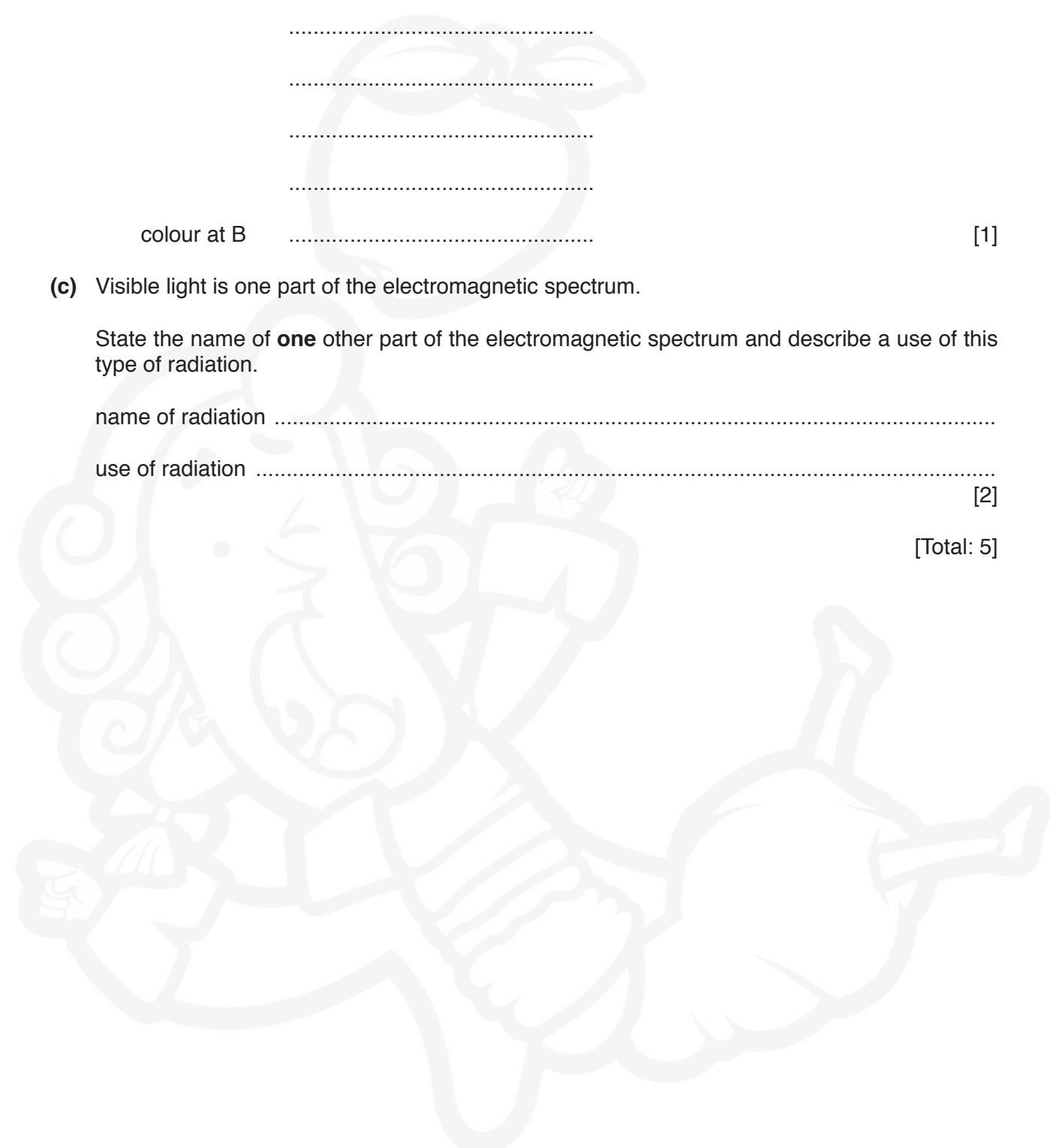

- 8 (a) Fig. 8.1 shows an incomplete ray diagram of a converging lens forming an image of the object, O.

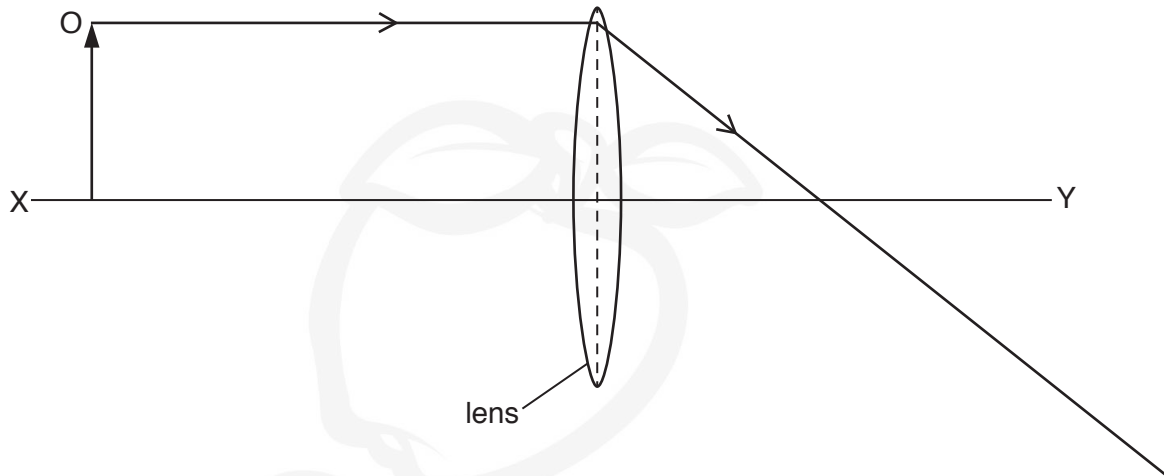

Fig. 8.1

- (i) State the term given to the line XY.

..... [1]

- (ii) On Fig. 8.1, indicate the position of one principal focus of the lens. Label the principal focus, F. [1]

- (b) (i) On Fig. 8.1, draw a ray of light from the top of the object that passes through the lens to form the image. Use a ruler. [2]

- (ii) On Fig. 8.1, draw the image formed by the lens. Label the image I. [1]

- (iii) Choose words from the box that describe the image formed by the lens in Fig. 8.1.

diminished	enlarged	horizontal	inverted	same size	upright
------------	----------	------------	----------	-----------	---------

Draw a ring around each correct word. [2]

[Total: 7]

- 9 (a) A student tests some materials to find which ones are electrical conductors. He uses the circuit in Fig. 9.1.

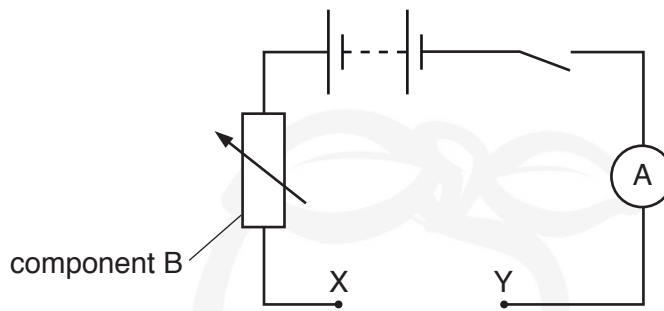

Fig. 9.1

- (i) State the name of component B.

..... [1]

- (ii) Describe how the student can use the circuit in Fig. 9.1 to test whether a material is an electrical conductor.

.....  
 .....  
 .....  
 ..... [2]

- (iii) State which materials are electrical conductors.

Put a tick in the box next to each material that is an electrical conductor.

plastic	<input type="checkbox"/>	copper	<input type="checkbox"/>
rubber	<input type="checkbox"/>	gold	<input type="checkbox"/>

[1]

- (b) The student connects a resistor R, between X and Y. The student determines the resistance of the resistor.

- (i) Name the instrument he uses to measure the potential difference (p.d.) across resistor R.

..... [1]

- (ii) The current in resistor R is 0.2A when the p.d. across the resistor is 6.0V. Calculate the resistance of resistor R.

resistance = .....  $\Omega$  [3]

[Total: 8]

- 10 Fig. 10.1 shows a desktop computer. The computer is connected to a mains supply by a plug containing a fuse.



Fig. 10.1

- (a) The computer has a metal case. A fault occurs and a live wire touches the metal case.

Explain how an earth wire and the fuse in the plug protect the user.

.....

.....

.....

.....

..... [3]

- (b) The computer contains a transformer. The input voltage to the transformer is 240V and the output voltage is 12.0V. The input coil of the transformer has 3000 turns.

Calculate the number of turns on the output coil.

number of turns = ..... [3]

[Total: 6]

- 11 (a) Table 11.1 includes information about the properties of three types of naturally occurring, nuclear radiation.

Table 11.1

type of radiation	charge	mass (atomic mass units)	nature
	0	0	electromagnetic wave
$\alpha$ (alpha)	+2		helium-4 nucleus
		1/2000	

Complete the table.

[4]

- (b) The graph shows the decay curve for a radioactive substance.

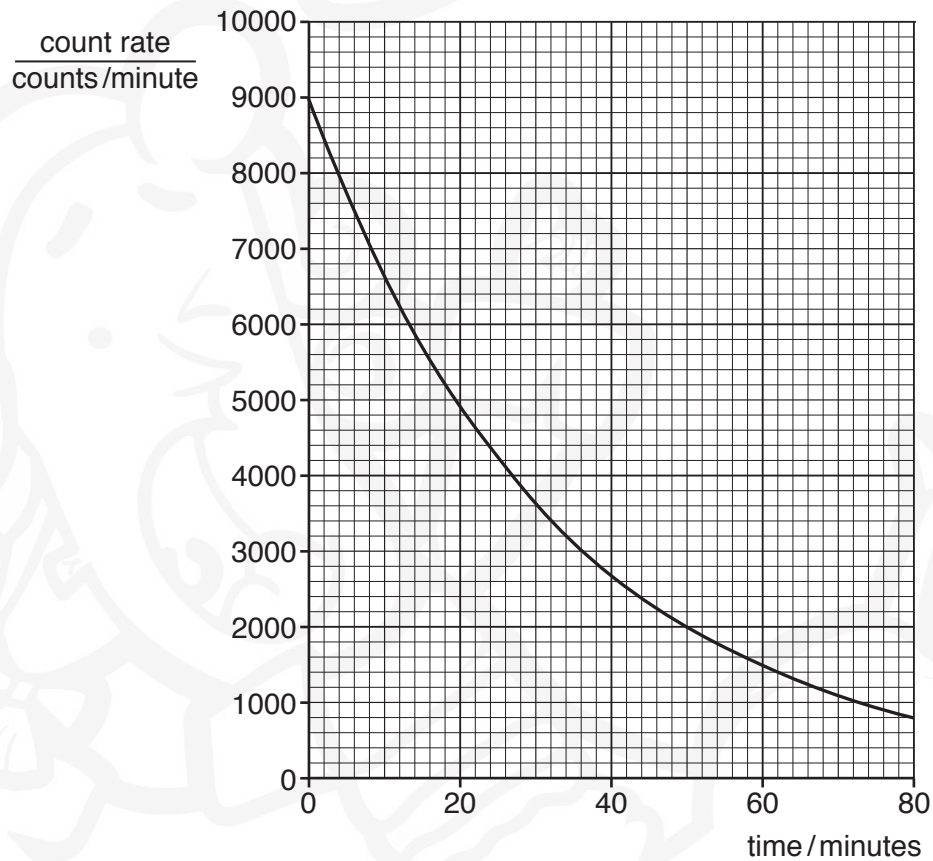

Use the graph to determine the half-life of the radioactive substance.

half-life = ..... minutes [3]

[Total: 7]

12 A student uses the equipment shown in Fig. 12.1.

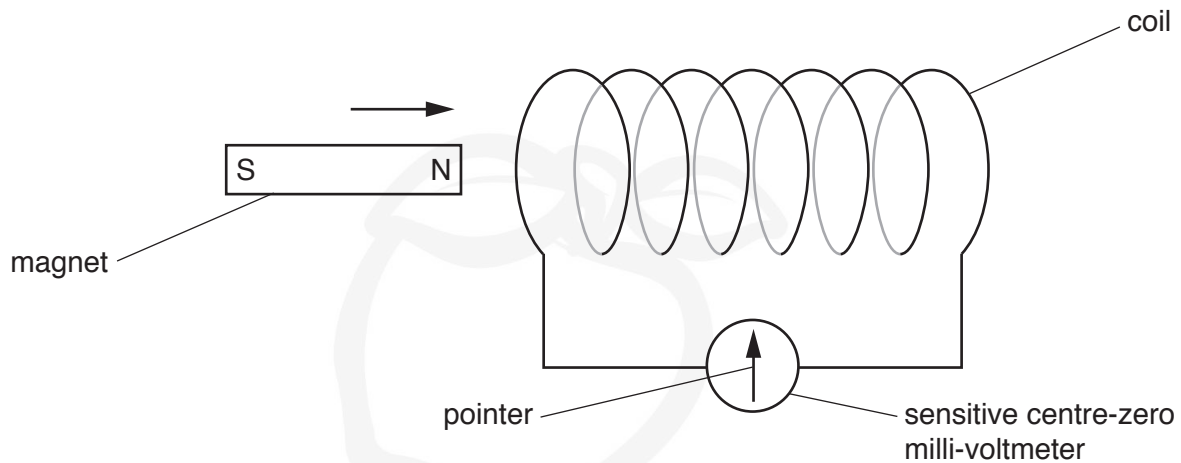

Fig. 12.1

The student moves the magnet to the right into the coil and then holds the magnet stationary for a few seconds. The pointer deflects to the right and then returns to the centre.

The student then moves the magnet to the left so that it is completely out of the coil and moves it far away from the coil.

(a) Describe how the pointer moves when the student moves the magnet out of the coil.

.....  
 ..... [2]

(b) Explain why the pointer behaves as described in (a).

.....  
 .....  
 .....  
 ..... [3]

[Total: 5]

Permission to reproduce items where third-party owned material protected by copyright is included has been sought and cleared where possible. Every reasonable effort has been made by the publisher (UCLES) to trace copyright holders, but if any items requiring clearance have unwittingly been included, the publisher will be pleased to make amends at the earliest possible opportunity.

To avoid the issue of disclosure of answer-related information to candidates, all copyright acknowledgements are reproduced online in the Cambridge Assessment International Education Copyright Acknowledgements Booklet. This is produced for each series of examinations and is freely available to download at [www.cambridgeinternational.org](http://www.cambridgeinternational.org) after the live examination series.

Cambridge Assessment International Education is part of the Cambridge Assessment Group. Cambridge Assessment is the brand name of the University of Cambridge Local Examinations Syndicate (UCLES), which itself is a department of the University of Cambridge.