



Cambridge International AS & A Level

PHYSICS

9702/12

Paper 1 Multiple Choice

February/March 2023

1 hour 15 minutes

You must answer on the multiple choice answer sheet.

You will need: Multiple choice answer sheet
Soft clean eraser
Soft pencil (type B or HB is recommended)

INSTRUCTIONS

- There are **forty** questions on this paper. Answer **all** questions.
- For each question there are four possible answers **A**, **B**, **C** and **D**. Choose the **one** you consider correct and record your choice in soft pencil on the multiple choice answer sheet.
- Follow the instructions on the multiple choice answer sheet.
- Write in soft pencil.
- Write your name, centre number and candidate number on the multiple choice answer sheet in the spaces provided unless this has been done for you.
- Do **not** use correction fluid.
- Do **not** write on any bar codes.
- You may use a calculator.

INFORMATION

- The total mark for this paper is 40.
- Each correct answer will score one mark.
- Any rough working should be done on this question paper.

This document has **20** pages. Any blank pages are indicated.



Data

acceleration of free fall	$g = 9.81 \text{ m s}^{-2}$
speed of light in free space	$c = 3.00 \times 10^8 \text{ m s}^{-1}$
elementary charge	$e = 1.60 \times 10^{-19} \text{ C}$
unified atomic mass unit	$1 \text{ u} = 1.66 \times 10^{-27} \text{ kg}$
rest mass of proton	$m_p = 1.67 \times 10^{-27} \text{ kg}$
rest mass of electron	$m_e = 9.11 \times 10^{-31} \text{ kg}$
Avogadro constant	$N_A = 6.02 \times 10^{23} \text{ mol}^{-1}$
molar gas constant	$R = 8.31 \text{ J K}^{-1} \text{ mol}^{-1}$
Boltzmann constant	$k = 1.38 \times 10^{-23} \text{ J K}^{-1}$
gravitational constant	$G = 6.67 \times 10^{-11} \text{ N m}^2 \text{ kg}^{-2}$
permittivity of free space	$\epsilon_0 = 8.85 \times 10^{-12} \text{ F m}^{-1}$ $(\frac{1}{4\pi\epsilon_0} = 8.99 \times 10^9 \text{ m F}^{-1})$
Planck constant	$h = 6.63 \times 10^{-34} \text{ J s}$
Stefan–Boltzmann constant	$\sigma = 5.67 \times 10^{-8} \text{ W m}^{-2} \text{ K}^{-4}$

Formulae

uniformly accelerated motion	$s = ut + \frac{1}{2}at^2$ $v^2 = u^2 + 2as$
hydrostatic pressure	$\Delta p = \rho g \Delta h$
upthrust	$F = \rho g V$
Doppler effect for sound waves	$f_o = \frac{f_s v}{v \pm v_s}$
electric current	$I = Anvq$
resistors in series	$R = R_1 + R_2 + \dots$
resistors in parallel	$\frac{1}{R} = \frac{1}{R_1} + \frac{1}{R_2} + \dots$

1 What represents a physical quantity?

- A 3.0
- B kilogram
- C 7.0 N
- D 40%

2 The relationship between the variables D and T is given by the equation

$$\frac{1}{T} = \frac{b}{\sqrt{D}} + c$$

where b and c are constants.

The unit of D is m^2 and the unit of T is s.

What are the units of b and c ?

	unit of b	unit of c
A	ms	s
B	m s^{-1}	s^{-1}
C	$\text{m}^{-1} \text{s}$	s
D	$\text{m}^{-1} \text{s}^{-1}$	s^{-1}

3 A hollow cylinder, which is open at both ends, has a radius of $(3.0 \pm 0.1)\text{cm}$ and a length of $(15.0 \pm 0.1)\text{cm}$.

What is the value, with its absolute uncertainty, of the surface area of the cylinder?

- A $(280 \pm 10)\text{cm}^2$
- B $(282.7 \pm 0.2)\text{cm}^2$
- C $(420 \pm 30)\text{cm}^2$
- D $(424.1 \pm 0.3)\text{cm}^2$

- 4 A snooker ball of mass 0.20 kg has a collision so that its direction of movement changes by an angle of 90° , as shown.

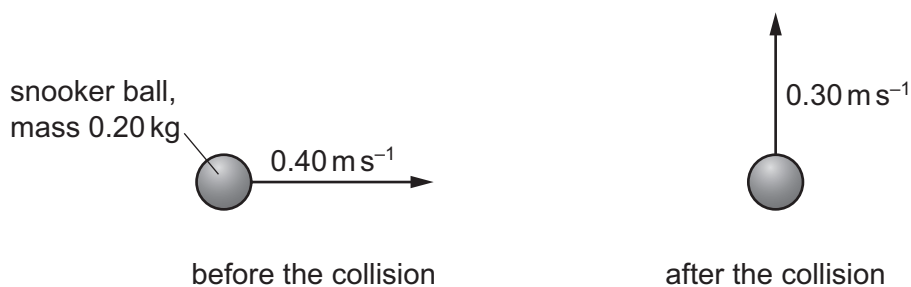

The ball has a speed of 0.40 m s^{-1} before the collision and a speed of 0.30 m s^{-1} after the collision.

What is the **magnitude** of the change in momentum of the snooker ball?

- A 0.020 kg m s^{-1}
 - B 0.10 kg m s^{-1}
 - C 0.14 kg m s^{-1}
 - D 0.50 kg m s^{-1}
- 5 A ball is kicked upwards at an angle of 45° to horizontal ground. After a short flight, the ball returns to the ground.

It may be assumed that air resistance is negligible.

What is **never** zero during the flight of the ball?

- A the horizontal component of the ball's acceleration
- B the horizontal component of the ball's velocity
- C the vertical component of the ball's momentum
- D the vertical component of the ball's velocity

- 6 The graph shows the variation with time t of the displacement s of an object.

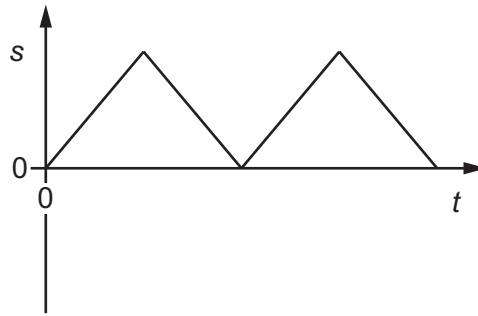

Which graph represents the variation with time t of the acceleration a of the object?

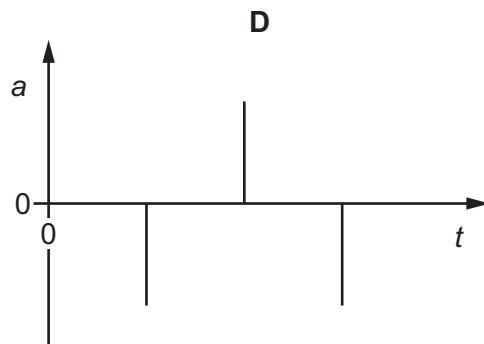
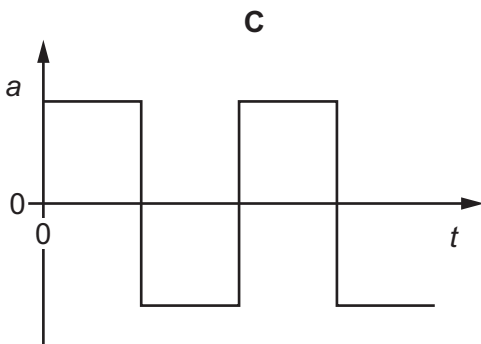
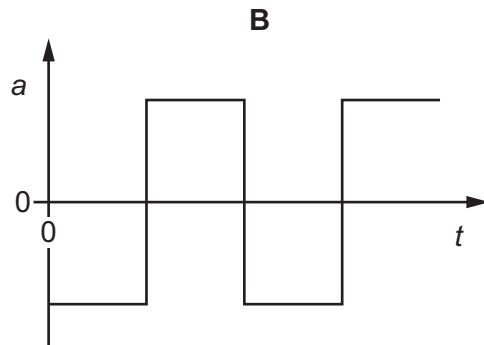
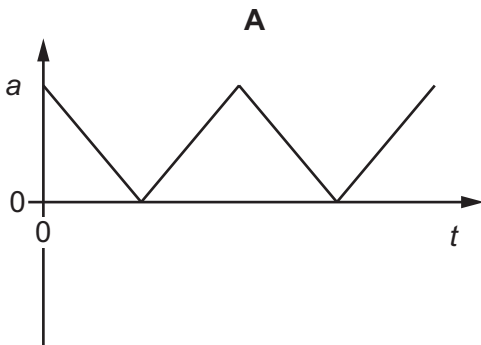

- 7 Which expression defines force?
- A** $(\text{mass} \times \text{change in speed}) \times \text{time taken}$
- B** $\frac{\text{mass} \times \text{change in speed}}{\text{time taken}}$
- C** $(\text{change of momentum}) \times \text{time taken}$
- D** $\frac{\text{change of momentum}}{\text{time taken}}$

- 8 A ship of mass $8.4 \times 10^7 \text{ kg}$ is approaching a harbour with speed 16.4 ms^{-1} . By using reverse thrust it can maintain a constant total stopping force of $920\,000 \text{ N}$.

How long will it take to stop?

- A 15 seconds
 B 150 seconds
 C 25 minutes
 D 250 minutes
- 9 The velocity–time graphs of four different objects are shown.

Which graph represents an object falling from rest through a long distance in the Earth's atmosphere?

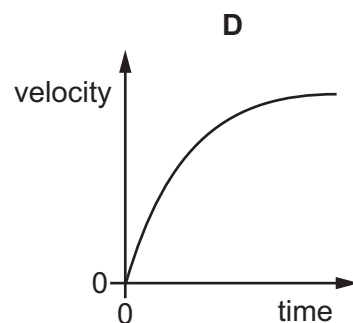
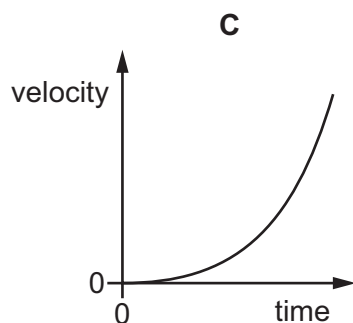
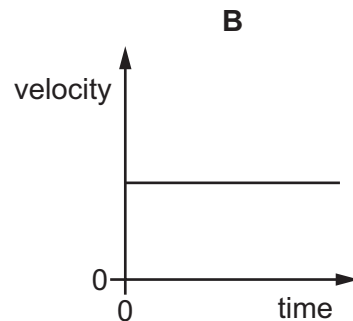
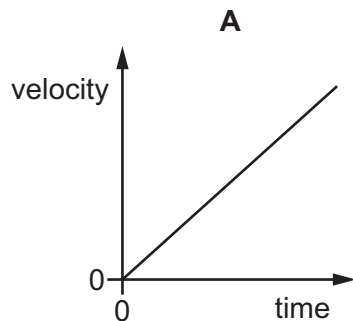

- 10 Which statement about collisions is correct?

- A Kinetic energy is conserved in all collisions.
 B Momentum is only conserved in perfectly elastic collisions.
 C The relative speed of approach is equal to the relative speed of separation for perfectly elastic collisions.
 D When two objects of different masses collide, they exert forces of different magnitudes on each other.

11 A satellite uses two thrusters to adjust its motion in space.

Each thruster exerts a force of 40 N on the satellite. The line of action of each force is a perpendicular distance of 2.3 m from the centre of gravity of the satellite. These two parallel forces act in opposite directions.

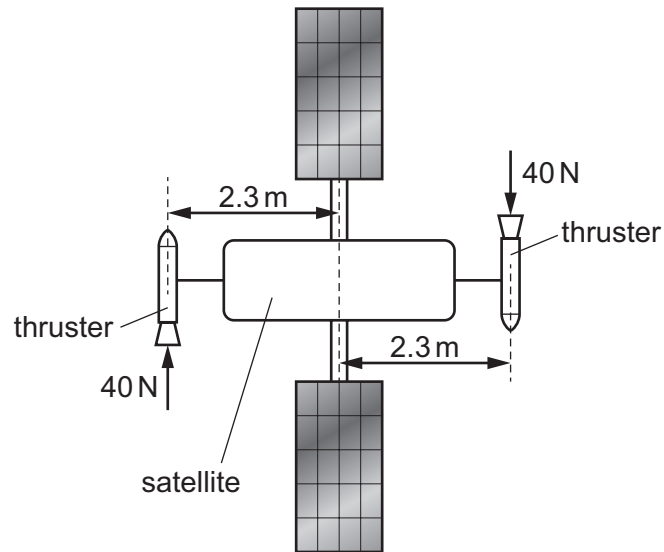

What are the magnitudes of the torque and the resultant force acting on the satellite due to the two thrust forces?

	torque /Nm	resultant force/N
A	92	0
B	92	80
C	180	0
D	180	80

12 The diagrams show two ways of hanging the same picture.

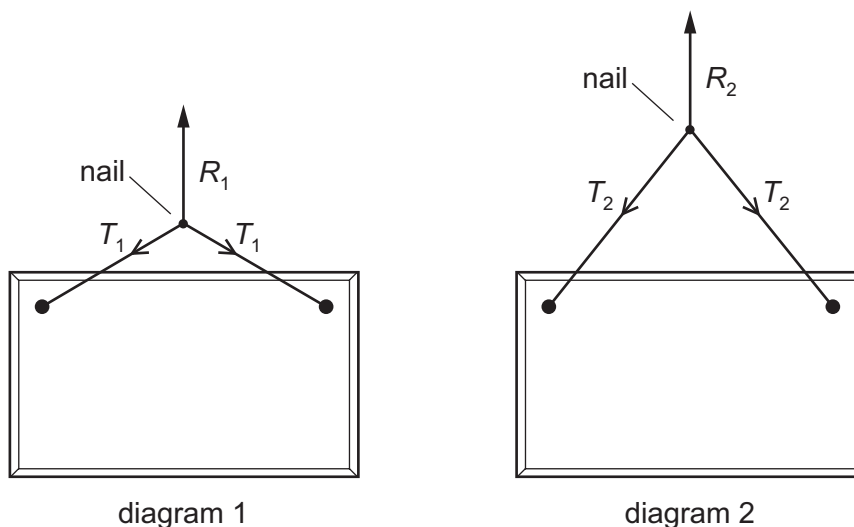

In both cases, a string is attached to the same points on the picture and looped symmetrically over a nail in a wall. The forces shown are those that act on the nail.

In diagram 1, the string loop is shorter than in diagram 2.

Which information about the magnitude of the forces is correct?

- A $R_1 = R_2$ $T_1 = T_2$
- B $R_1 = R_2$ $T_1 > T_2$
- C $R_1 > R_2$ $T_1 < T_2$
- D $R_1 < R_2$ $T_1 = T_2$

13 An object shaped as a hemisphere rests with its flat surface on a table. The object has radius r and density ρ .

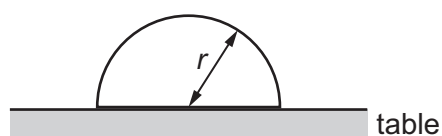

The volume of a sphere is $\frac{4}{3}\pi r^3$.

Which average pressure does the object exert on the table?

- A $\frac{1}{3}\rho r^2$
- B $\frac{1}{3}\rho r^2 g$
- C $\frac{2}{3}\rho r$
- D $\frac{2}{3}\rho r g$

- 14 A probe is used to monitor the quality of the water in the sea. The probe is suspended by a vertical string which is attached to a sphere. The stationary sphere floats in equilibrium on the surface of the sea, as shown.

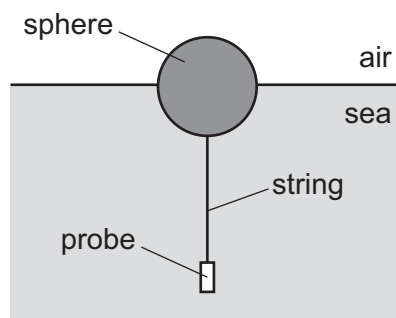

The sphere has a weight of 5.00 N. The probe and string have a combined weight of 2.00 N.

The density of the seawater is $1.03 \times 10^3 \text{ kg m}^{-3}$. The upthrust acting on the probe and thread is negligible.

What is the volume of the sphere below the surface of the sea?

- A $1.98 \times 10^{-4} \text{ m}^3$
 B $2.97 \times 10^{-4} \text{ m}^3$
 C $4.95 \times 10^{-4} \text{ m}^3$
 D $6.93 \times 10^{-4} \text{ m}^3$
- 15 What is the centre of gravity of an object?
- A the geometrical centre of the object
 B the point at which the weight of the object may be considered to act
 C the point on the object about which there is a zero net torque
 D the point where gravity acts on the object
- 16 A system with an efficiency of 74% wastes 230 W of power.
- What is the useful output power of the system?
- A 170 W B 310 W C 650 W D 880 W
- 17 A projectile of mass 0.25 kg is at a height of 30 m above horizontal ground and travelling at a speed of 15 m s^{-1} . A short time later, it is at a height of 35 m above the horizontal ground and travelling at a speed of 5.0 m s^{-1} .
- How much work is done against air resistance during this time?
- A 0 J B 13 J C 25 J D 37 J

- 18 A spring has an unstretched length of 4.50 cm. The spring is fixed at one end and a force of 35.0 N is applied to the other end so that the spring extends.

The spring obeys Hooke's law and has a spring constant of 420 N m^{-1} .

What is the strain of the extended spring?

- A 0.019 B 0.083 C 1.85 D 2.67
- 19 A wire is fixed at one end and extended by a force that is applied to the other end. The force is slowly increased from zero and then slowly decreased back to zero.

The force–extension graph for the wire is shown.

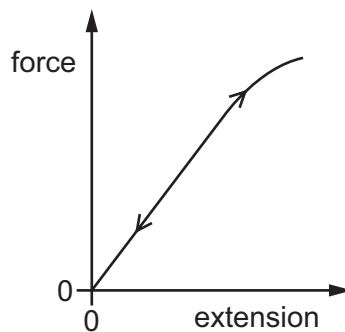

The graph line for the wire being loaded is the same as the graph line for the wire being unloaded.

Which statement describes the deformation of the wire?

- A It is both elastic and plastic.
B It is elastic only.
C It is neither elastic nor plastic.
D It is plastic only.

- 20 In a progressive water wave, two particles, P and Q, on the surface of the water, are a fixed horizontal distance apart. P and Q oscillate vertically.

At time $t = 0$, the wave is as shown.

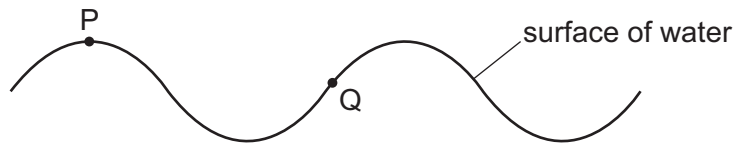

Which graph best represents the variation with time t of the phase difference ϕ between the oscillation of the water particle P and the oscillation of the water particle Q?

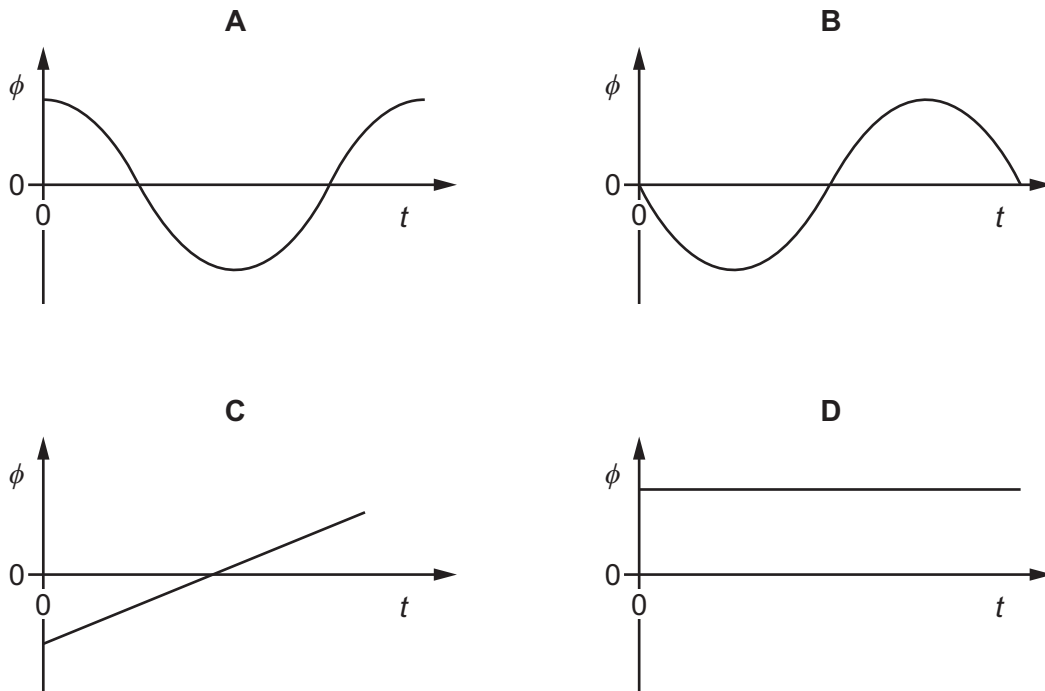

- 21 Which statement about longitudinal waves and transverse waves is **not** correct?

- A Both waves can be polarised.
- B Both waves can form stationary waves.
- C Both waves can transfer energy as progressive waves.
- D Both waves obey the equation $v = f\lambda$.

22 An observer hears a sound wave emitted from a moving source.

The observed frequency is less than the frequency of sound emitted from the source.

What could be the reason for this?

- A The source is moving away from the observer.
- B The source is moving towards the observer.
- C The speed of the sound wave in air decreases due to the movement of the source.
- D The speed of the sound wave in air increases due to the movement of the source.

23 What is the approximate range of frequencies of electromagnetic radiation visible to the human eye?

- A (430–750) kHz
- B (430–750) MHz
- C (430–750) GHz
- D (430–750) THz

24 A beam of vertically polarised light is incident normally on a polarising filter. The filter can be rotated so that it is always in a plane perpendicular to the beam. The transmission axis of the filter is initially vertical.

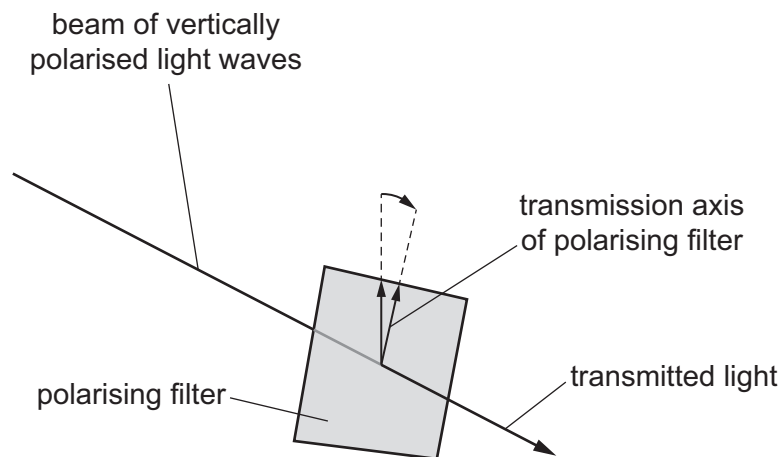

The filter is first rotated clockwise by an angle of 30° so that the transmitted light waves have intensity I_{30} . The filter is then rotated clockwise by a further angle of 30° .

What is the new intensity of the transmitted light waves?

- A $0.25 I_{30}$
- B $0.33 I_{30}$
- C $0.75 I_{30}$
- D $0.87 I_{30}$

- 25 A musical instrument is made using a long tube with a mouthpiece at one end. The other end is open and flared, as shown.

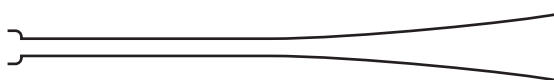

A musician maintains stationary sound waves with a node at the mouthpiece and an antinode at the other end. The lowest frequency of sound that the instrument can produce is 92 Hz.

Which different frequencies of sound can be produced by the instrument?

- A 92 Hz, 138 Hz, 184 Hz, 230 Hz
 B 92 Hz, 184 Hz, 276 Hz, 368 Hz
 C 92 Hz, 276 Hz, 460 Hz, 644 Hz
 D 92 Hz, 276 Hz, 828 Hz, 1288 Hz
- 26 Two waves of equal frequency and amplitude are travelling in opposite directions along a stretched string. When they meet, they form a stationary wave with three nodes and two antinodes.

The frequency of both waves is doubled and a new stationary wave is formed.

How many antinodes are there in the new stationary wave?

- A 1 B 2 C 3 D 4
- 27 A transmitting mast sends out microwaves of wavelength 1.5 cm and radio waves of wavelength 1.5 km.

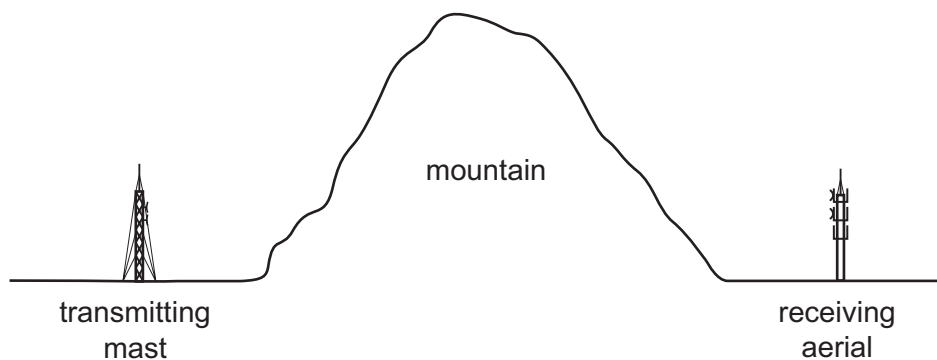

NOT TO SCALE

A receiving aerial behind a mountain can detect the radio waves but not the microwaves.

What is the reason for this?

- A The radio waves are coherent but the microwaves are not.
 B The radio waves are diffracted around the mountain but the microwaves are not.
 C The radio waves are reflected by the mountain but the microwaves are not.
 D The radio waves travel at the speed of light but the microwaves do not.

28 Waves are emitted from two coherent sources.

Which statement about the waves must be correct?

- A They are in phase.
- B They are transverse waves.
- C They have a constant phase difference.
- D They have the same amplitude.

29 The diagram shows a screen that is a distance L from a diffraction grating. The grating has a total number of N lines. Any two adjacent lines are a distance d apart. A beam of parallel light of wavelength λ is incident normally on the grating.

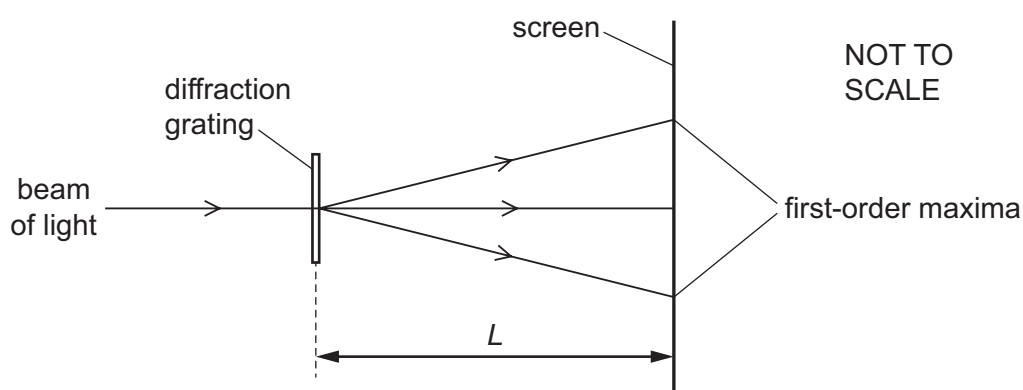

Which quantities affect the distance between the first-order diffraction maxima on the screen?

	d	λ	L	N
A	✓	✓	✓	✗
B	✓	✓	✗	✗
C	✓	✗	✓	✓
D	✗	✓	✗	✓

key

✓ = affects the distance

✗ = does not affect the distance

30 A wire carries a current of $0.10\ \mu\text{A}$. The potential difference across the wire is $10\ \text{mV}$.

How much energy is dissipated by the wire in a time of $10\ \text{s}$?

- A $1.0\ \text{pJ}$
- B $10\ \text{pJ}$
- C $1.0\ \text{nJ}$
- D $10\ \text{nJ}$

31 What is the definition of the potential difference across an electrical component?

- A energy transferred per unit charge
- B energy transferred per unit current
- C energy transferred per unit resistance
- D energy transferred per unit time

- 32 Which graph represents the way the current I through a filament lamp varies with the potential difference V across it?

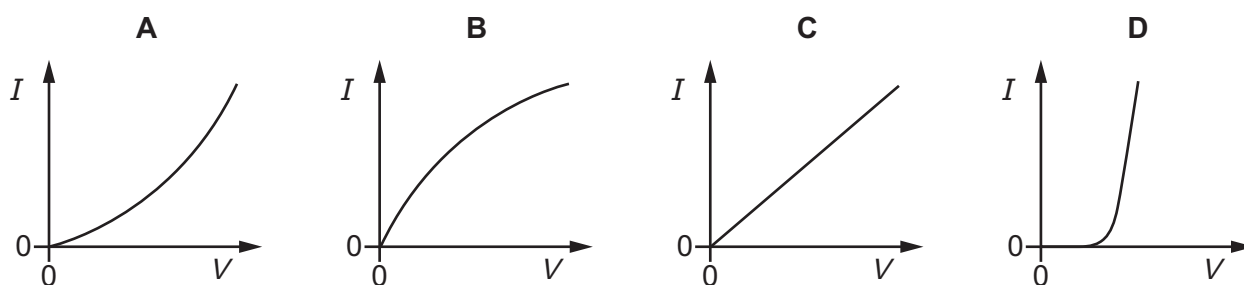

- 33 The table shows the properties of two different wires, P and Q.

	length	resistance	resistivity of material
wire P	l	R	ρ
wire Q	$2l$	$\frac{1}{4}R$	$\frac{1}{3}\rho$

Wire P has a cross-section of diameter d .

What is the diameter of the cross-section of wire Q?

- A** $0.41d$ **B** $1.6d$ **C** $2.7d$ **D** $7.1d$
- 34 A cell has a constant electromotive force.
A variable resistor is connected between the terminals of the cell.
The resistance of the variable resistor is decreased.
Which statement about the change of the cell's terminal potential difference (p.d.) is correct?
- A** The terminal p.d. is decreased because more work is done moving unit charge through the internal resistance of the cell.
B The terminal p.d. is decreased because the current in the variable resistor is decreased.
C The terminal p.d. is increased because more work is done moving unit charge through the variable resistor.
D The terminal p.d. is increased because the current in the variable resistor is increased.

35 Kirchhoff's two laws for electric circuits can be derived by using conservation laws.

On which conservation laws do Kirchhoff's laws depend?

	Kirchhoff's first law	Kirchhoff's second law
A	charge	current
B	charge	energy
C	current	mass
D	energy	current

36 A battery of electromotive force (e.m.f.) 10V and internal resistance r is connected to three resistors of resistances R , 2.0Ω and 15Ω , as shown. A current of 0.45A is in the resistor of resistance 2.0Ω and a current of 0.48A is in the resistor of resistance 15Ω .

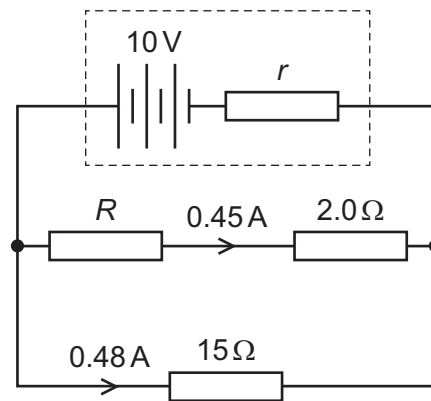

What are the values of r and R ?

	r/Ω	R/Ω
A	3.0	14
B	3.0	20
C	5.8	14
D	5.8	20

- 37 A battery of negligible internal resistance is connected in series with a thermistor and a fixed resistor of resistance $12.0\text{ k}\Omega$, as shown.

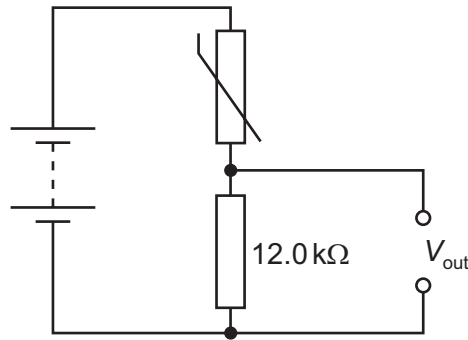

The table shows the resistance of the thermistor at two different temperatures.

temperature / $^{\circ}\text{C}$	resistance of thermistor / $\text{k}\Omega$
20.0	12.0
50.0	5.00

The potential difference V_{out} across the fixed resistor is 4.50 V when the thermistor is at a temperature of 20.0°C .

What is V_{out} when the thermistor is at a temperature of 50.0°C ?

- A** 2.65 V **B** 3.18 V **C** 6.35 V **D** 10.8 V
- 38 What is a conclusion from the alpha-particle scattering experiment?
- A** Protons and electrons have equal but opposite charges.
B Protons have a much larger mass than electrons.
C The nucleus contains most of the mass of the atom.
D The nucleus of an atom contains protons and neutrons.

- 39 Americium-241 is a radioactive nuclide used in smoke detectors. It undergoes α -decay to form nuclide X. This decay may be represented by the equation shown.

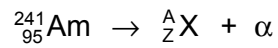

What are the values of A and Z?

	A	Z
A	237	93
B	239	91
C	241	94
D	241	96

- 40 A top quark has a charge of $+\frac{2}{3}e$, where e is the elementary charge.

What is the charge of an anti top quark?

- A** $-\frac{2}{3}e$ **B** $-\frac{1}{3}e$ **C** $+\frac{1}{3}e$ **D** $+\frac{2}{3}e$

BLANK PAGE

Permission to reproduce items where third-party owned material protected by copyright is included has been sought and cleared where possible. Every reasonable effort has been made by the publisher (UCLES) to trace copyright holders, but if any items requiring clearance have unwittingly been included, the publisher will be pleased to make amends at the earliest possible opportunity.

To avoid the issue of disclosure of answer-related information to candidates, all copyright acknowledgements are reproduced online in the Cambridge Assessment International Education Copyright Acknowledgements Booklet. This is produced for each series of examinations and is freely available to download at www.cambridgeinternational.org after the live examination series.

Cambridge Assessment International Education is part of Cambridge Assessment. Cambridge Assessment is the brand name of the University of Cambridge Local Examinations Syndicate (UCLES), which is a department of the University of Cambridge.