



Cambridge International AS & A Level

PHYSICS

9702/12

Paper 1 Multiple Choice

February/March 2021

1 hour 15 minutes

You must answer on the multiple choice answer sheet.

You will need: Multiple choice answer sheet
Soft clean eraser
Soft pencil (type B or HB is recommended)

INSTRUCTIONS

- There are **forty** questions on this paper. Answer **all** questions.
- For each question there are four possible answers **A**, **B**, **C** and **D**. Choose the **one** you consider correct and record your choice in soft pencil on the multiple choice answer sheet.
- Follow the instructions on the multiple choice answer sheet.
- Write in soft pencil.
- Write your name, centre number and candidate number on the multiple choice answer sheet in the spaces provided unless this has been done for you.
- Do **not** use correction fluid.
- Do **not** write on any bar codes.
- You may use a calculator.

INFORMATION

- The total mark for this paper is 40.
- Each correct answer will score one mark.
- Any rough working should be done on this question paper.

This document has **20** pages. Any blank pages are indicated.



Data

speed of light in free space	$c = 3.00 \times 10^8 \text{ m s}^{-1}$
permeability of free space	$\mu_0 = 4\pi \times 10^{-7} \text{ H m}^{-1}$
permittivity of free space	$\epsilon_0 = 8.85 \times 10^{-12} \text{ F m}^{-1}$ $(\frac{1}{4\pi\epsilon_0} = 8.99 \times 10^9 \text{ m F}^{-1})$
elementary charge	$e = 1.60 \times 10^{-19} \text{ C}$
the Planck constant	$h = 6.63 \times 10^{-34} \text{ J s}$
unified atomic mass unit	$1 \text{ u} = 1.66 \times 10^{-27} \text{ kg}$
rest mass of electron	$m_e = 9.11 \times 10^{-31} \text{ kg}$
rest mass of proton	$m_p = 1.67 \times 10^{-27} \text{ kg}$
molar gas constant	$R = 8.31 \text{ J K}^{-1} \text{ mol}^{-1}$
the Avogadro constant	$N_A = 6.02 \times 10^{23} \text{ mol}^{-1}$
the Boltzmann constant	$k = 1.38 \times 10^{-23} \text{ J K}^{-1}$
gravitational constant	$G = 6.67 \times 10^{-11} \text{ N m}^2 \text{ kg}^{-2}$
acceleration of free fall	$g = 9.81 \text{ m s}^{-2}$

Formulae

uniformly accelerated motion	$s = ut + \frac{1}{2}at^2$ $v^2 = u^2 + 2as$
work done on/by a gas	$W = p\Delta V$
gravitational potential	$\phi = -\frac{Gm}{r}$
hydrostatic pressure	$p = \rho gh$
pressure of an ideal gas	$p = \frac{1}{3}\frac{Nm}{V}\langle c^2 \rangle$
simple harmonic motion	$a = -\omega^2 x$
velocity of particle in s.h.m.	$v = v_0 \cos \omega t$ $v = \pm \omega \sqrt{(x_0^2 - x^2)}$
Doppler effect	$f_o = \frac{f_s v}{v \pm v_s}$
electric potential	$V = \frac{Q}{4\pi\epsilon_0 r}$
capacitors in series	$1/C = 1/C_1 + 1/C_2 + \dots$
capacitors in parallel	$C = C_1 + C_2 + \dots$
energy of charged capacitor	$W = \frac{1}{2}QV$
electric current	$I = Anvq$
resistors in series	$R = R_1 + R_2 + \dots$
resistors in parallel	$1/R = 1/R_1 + 1/R_2 + \dots$
Hall voltage	$V_H = \frac{BI}{ntq}$
alternating current/voltage	$x = x_0 \sin \omega t$
radioactive decay	$x = x_0 \exp(-\lambda t)$
decay constant	$\lambda = \frac{0.693}{t_{\frac{1}{2}}}$

- 1 What is a reasonable estimate for the density of sand?
- A $2 \times 10^2 \text{ g cm}^{-3}$
 B $2 \times 10^3 \text{ g cm}^{-3}$
 C $2 \times 10^1 \text{ kg m}^{-3}$
 D $2 \times 10^3 \text{ kg m}^{-3}$
- 2 Which physical quantity could have units of $\text{N s}^2 \text{ m}^{-1}$?
- A acceleration
 B force
 C mass
 D momentum
- 3 A velocity vector is shown.

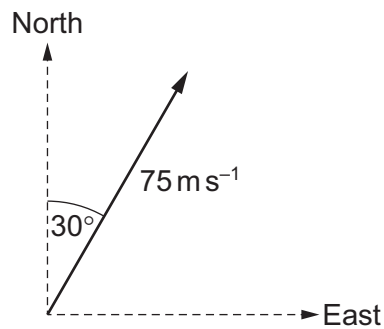

What are the components of the velocity vector in the northerly and in the easterly directions?

	component of vector in northerly direction $/ \text{ms}^{-1}$	component of vector in easterly direction $/ \text{ms}^{-1}$
A	38	38
B	38	65
C	65	38
D	65	65

- 4 A micrometer screw gauge is used to measure the diameter of a copper wire.

The reading with the wire in position is shown in diagram 1. The wire is removed and the jaws of the micrometer are closed. The new reading is shown in diagram 2.

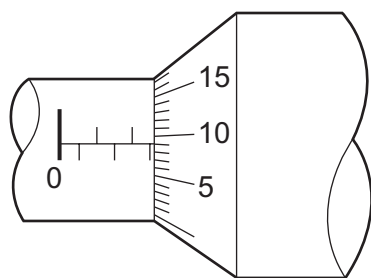

diagram 1

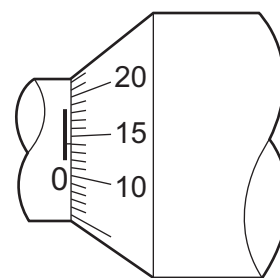

diagram 2

What is the diameter of the wire?

- A** 1.95 mm **B** 2.45 mm **C** 2.59 mm **D** 2.73 mm
- 5 A student measures the current and the potential difference for a resistor in a circuit.

$$\text{current} = (50.00 \pm 0.01) \text{ mA}$$

$$\text{potential difference} = (500.0 \pm 0.1) \text{ mV}$$

The measurements are used to calculate the resistance of the resistor.

What is the percentage uncertainty in the calculated resistance?

- A** 0.0002% **B** 0.0004% **C** 0.02% **D** 0.04%
- 6 Four cars, **A**, **B**, **C** and **D**, move from rest in a straight line. The cars take the same time to accelerate to a velocity of 60 km h^{-1} . Their velocity–time graphs are shown.

Which car reaches a velocity of 60 km h^{-1} in the shortest distance?

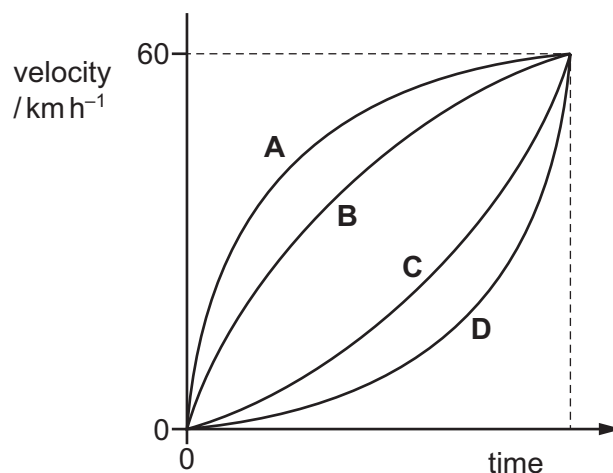

- 7 A cannon fires a cannonball with an initial speed v at an angle α to the horizontal.

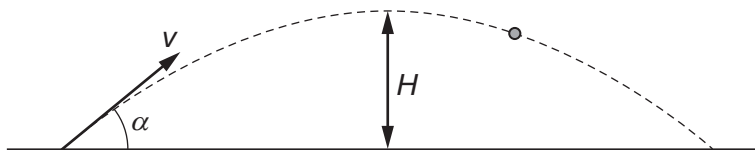

Which equation is correct for the maximum height H reached?

- A $H = \frac{v \sin \alpha}{2g}$ B $H = \frac{g \sin \alpha}{2v}$ C $H = \frac{(v \sin \alpha)^2}{2g}$ D $H = \frac{g^2 \sin \alpha}{2v}$

- 8 A ball strikes a horizontal surface with momentum p at an angle θ to the surface, as shown.

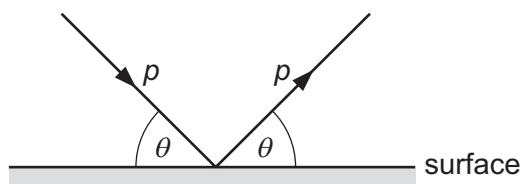

The ball rebounds with the same magnitude of momentum at an angle θ to the surface.

The ball is in contact with the surface for time t .

What is the magnitude of the average resultant force acting on the ball during the collision?

- A zero B $\frac{2p}{t}$ C $\frac{2p \cos \theta}{t}$ D $\frac{2p \sin \theta}{t}$

- 9 A skydiver, who is falling vertically through the air, opens his parachute.

Which row describes the velocity of the skydiver immediately after he opens his parachute?

	direction of velocity	magnitude of velocity
A	downwards	decreases
B	downwards	increases
C	upwards	decreases
D	upwards	increases

- 10 A stationary firework explodes into four fragments which travel in different directions in a horizontal plane. The diagram shows the velocity and mass of each fragment.

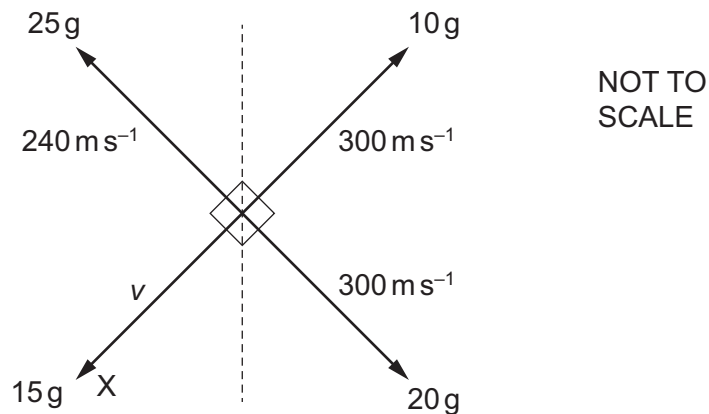

What is the speed v of fragment X?

- A 200 ms^{-1} B 240 ms^{-1} C 300 ms^{-1} D 360 ms^{-1}
- 11 A particle with mass moves in a horizontal straight line through a uniform electric field in a vacuum. The electric field is vertical.

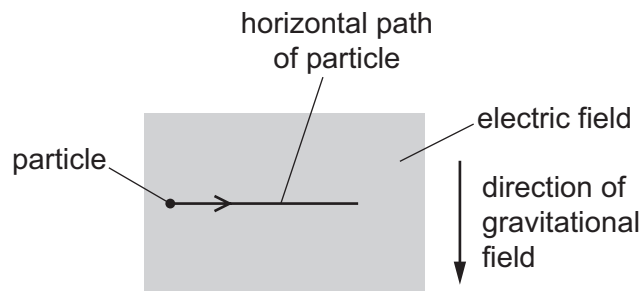

There is a significant gravitational effect on the motion of the particle.

What could be the direction of the electric field and the sign of the charge, if any, on the particle?

	electric field direction	sign of charge
A	downwards	negative
B	downwards	positive
C	upwards	negative
D	upwards	no charge

- 12 Two parallel forces, each of magnitude F , act on a rod of length $5d$.

Which diagram shows the positions of the two forces that will produce the largest torque on the rod?

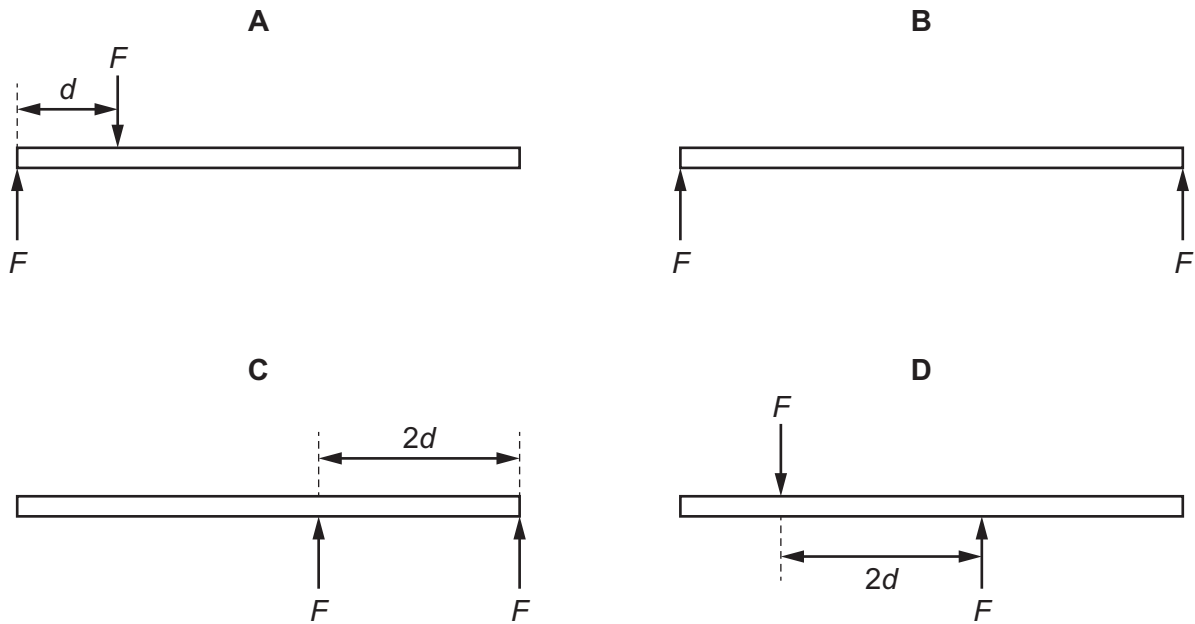

- 13 A mass of 30 kg is suspended from the end of a wire. A horizontal force F acts on the mass so that it is in equilibrium, with the wire at an angle of 30° to the vertical, as shown.

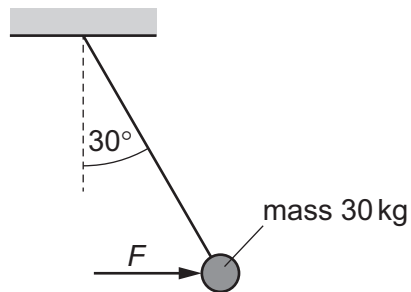

What is the magnitude of F ?

- A 17 N B 150 N C 170 N D 510 N

- 14 A balance is used to measure the mass m of a number of cylindrical metal rods of length l . All the metal rods have the same radius r .

The graph shows the variation with l of m .

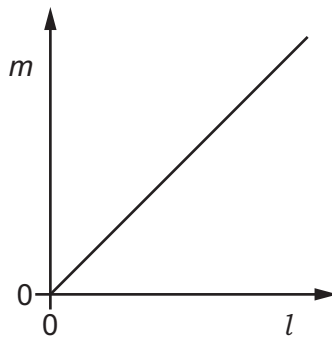

The gradient of the graph is G .

Which expression gives the density of the metal?

- A $\frac{G}{2\pi r}$ B $G2\pi r$ C $\frac{G}{\pi r^2}$ D $G\pi r^2$
- 15 Two blocks, X and Y, are on a horizontal frictionless surface. The mass of block Y is greater than that of block X. Block Y has a spring attached to its end.

The blocks are pushed together so that the spring is compressed between them and the blocks are held stationary as shown.

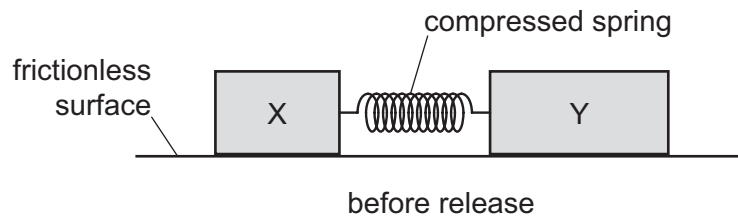

When released, the blocks move in opposite directions.

Which statement is correct?

- A After release, the kinetic energy of block X must equal the kinetic energy of block Y.
 B After release, the sum of the kinetic energies of the blocks is equal to zero.
 C The total energy of the spring and blocks immediately before release is zero.
 D The total energy of the spring and blocks is equal to the energy needed to bring the blocks together.

- 16 A gas is contained in a cylinder by a movable piston.

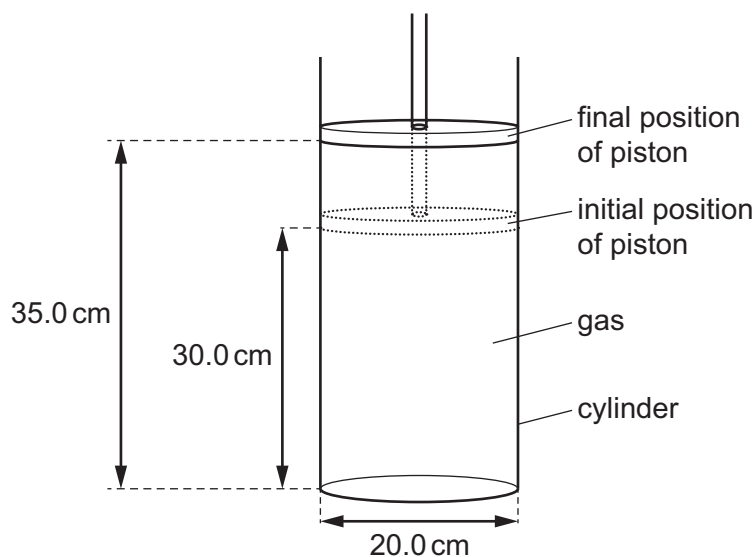

The cylinder has a circular cross-section of diameter 20.0 cm.

The pressure of the gas is 102 Pa and the piston is initially 30.0 cm from the base of the cylinder.

The gas is heated causing the piston to move up so that it is 35.0 cm from the base. The pressure of the gas remains constant.

How much work does the gas do in moving the piston?

- A** 0.160 J **B** 0.641 J **C** 1.12 J **D** 4.49 J
- 17 An egg of mass 25 g falls vertically downwards from the surface of a table which is 900 mm above the ground. Air resistance is negligible.
- What is the kinetic energy of the egg when it hits the ground?
- A** 0.023 J **B** 0.22 J **C** 23 J **D** 220 J
- 18 An aircraft travels at a constant velocity of 90 m s^{-1} in horizontal flight. The diagram shows the horizontal forces acting on the aircraft.

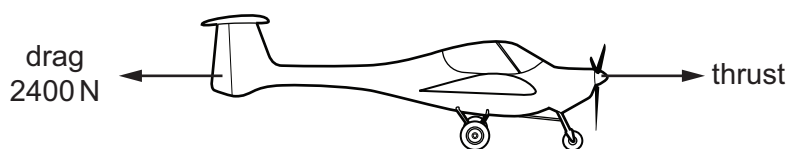

The mass of the aircraft is 2000 kg.

What is the power produced by the thrust force?

- A** $1.8 \times 10^5 \text{ W}$ **B** $2.2 \times 10^5 \text{ W}$ **C** $1.8 \times 10^6 \text{ W}$ **D** $2.0 \times 10^6 \text{ W}$

19 Which expression is equal to the stress on a wire?

A $\frac{\text{extension}}{\text{original length}}$

B $\frac{\text{force}}{\text{cross-sectional area}}$

C $\frac{\text{force}}{\text{extension}}$

D $\frac{\text{Young modulus}}{\text{original length}}$

20 A wire is stretched by applying increasing values of force F . For each value of force applied, the extension x is recorded. A force–extension graph is plotted from the data obtained.

Which statement about the area under the graph **must** be correct?

A It can be calculated as $\frac{1}{2}Fx$.

B It is the elastic potential energy stored in the stretched sample.

C It is the work done in stretching the sample.

D It would be the same for any wire of the same material.

21 A progressive radio wave in a vacuum has a frequency of 75 MHz.

What is the phase difference between two points on the wave that are 50 cm apart from each other?

A 23°

B 45°

C 90°

D 180°

22 Which statement is correct for longitudinal waves but **not** correct for transverse waves?

A They can form stationary waves.

B They can only travel through a medium.

C They can transfer energy in the direction of travel.

D They consist of peaks and troughs.

- 23 A loudspeaker emitting a sound wave of a single frequency is placed a distance L from a reflecting surface, as shown.

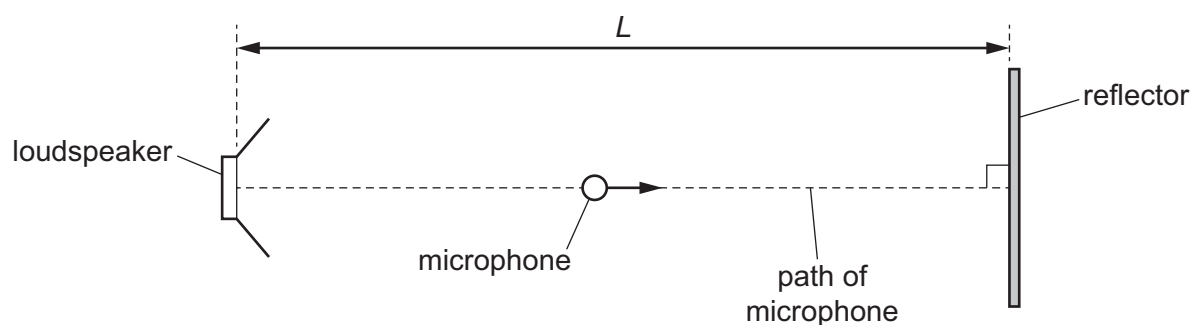

A stationary wave is formed with an antinode at the loudspeaker. A microphone is moved from the loudspeaker to the reflector.

Before the microphone reaches the reflector, it detects four points where the sound intensity is a minimum.

What is the wavelength of the sound wave?

- A $\frac{2L}{9}$ B $\frac{2L}{8}$ C $\frac{4L}{9}$ D $\frac{4L}{8}$
- 24 A source of sound of frequency F at point Z is moving at a steady speed. The pattern of the emitted wavefronts is shown.

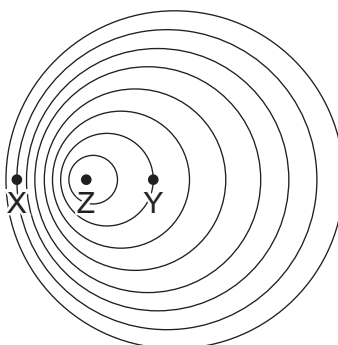

Which row describes the frequencies of the sound heard by stationary observers at X and Y?

	frequency heard at X	frequency heard at Y
A	$<F$	$<F$
B	$<F$	$>F$
C	$>F$	$<F$
D	$>F$	$>F$

- 25 What is **not** a possible value for the wavelength of the named electromagnetic waves when it is travelling in a vacuum?

	electromagnetic wave	wavelength / m
A	γ -rays	3×10^{-13}
B	X-rays	3×10^{-10}
C	infrared	3×10^{-6}
D	microwaves	3×10^{-5}

- 26 Two waves, P and Q, meet at a point X and superpose.

Initially, the two waves meet at X in phase (zero phase difference) so that the resultant wave has an amplitude of 14.0 cm at that point.

The phase difference between the two waves is then changed so that they meet at X with a phase difference of 180° . The resultant wave now has an amplitude of 4.0 cm at X.

What is the amplitude of one of the waves at point X?

- A** 2.0 cm **B** 5.0 cm **C** 10 cm **D** 18 cm
- 27 A water wave is diffracted as it passes through a gap between two barriers in a ripple tank. The wave is observed to 'spread out' as it moves through the gap.

Which two factors both affect the amount of diffraction observed?

- A** the amplitude and frequency of the incident wave
B the amplitude of the incident wave and the width of the gap
C the wavelength and amplitude of the incident wave
D the wavelength of the incident wave and the width of the gap

- 28 Two sources of microwaves P and Q produce coherent waves with a phase difference of 180° . The waves have the same wavelength λ .

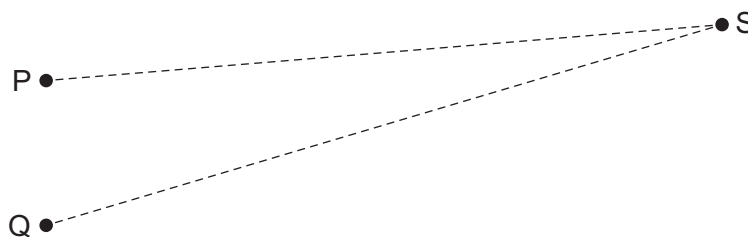

At the point S there is a minimum in the interference pattern produced by waves from the two sources. The distance $(QS - PS)$ is called the path difference.

Which expression could represent the path difference?

- A $\frac{\lambda}{4}$ B $\frac{\lambda}{2}$ C λ D $\frac{3\lambda}{2}$
- 29 A beam of red laser light of wavelength 633 nm is incident normally on a diffraction grating with 600 lines per mm.

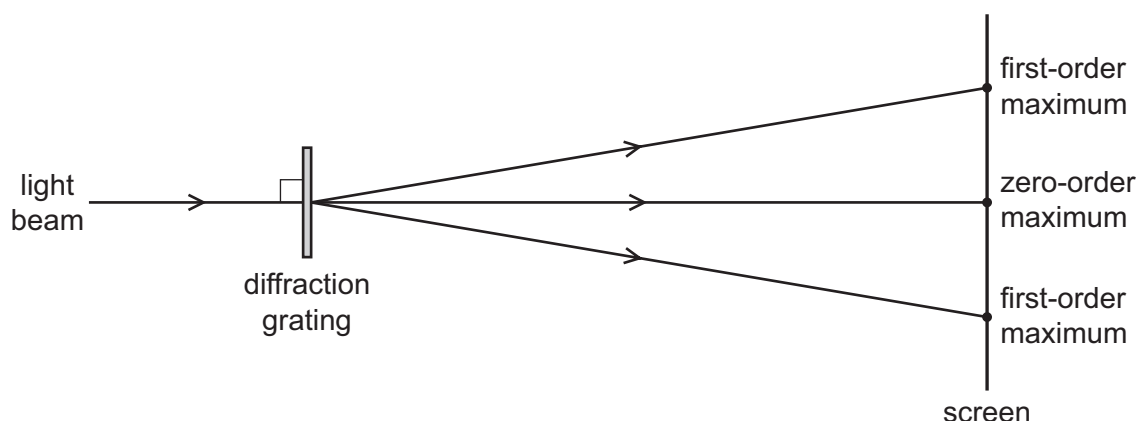

The beam of red light is now replaced by a beam of blue laser light of wavelength 445 nm. A replacement diffraction grating is used so that the first-order maximum of the blue light appears at the same position on the screen as the first-order maximum of the red light from the original laser.

How many lines per mm are there in the replacement diffraction grating?

- A 420 mm^{-1} B 470 mm^{-1} C 600 mm^{-1} D 850 mm^{-1}

- 30 Which diagram best represents the field lines in the electric field produced by a combination of one point positive charge and one point negative charge?

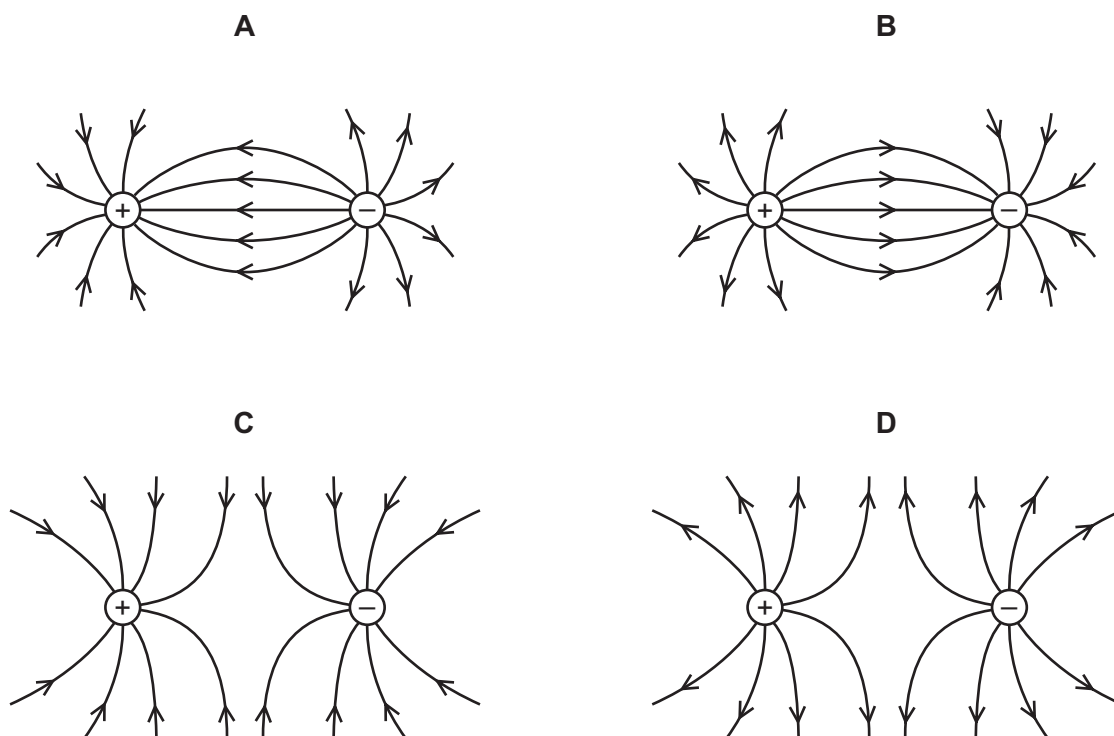

- 31 The diagram shows a thundercloud whose base is 500 m above the ground.

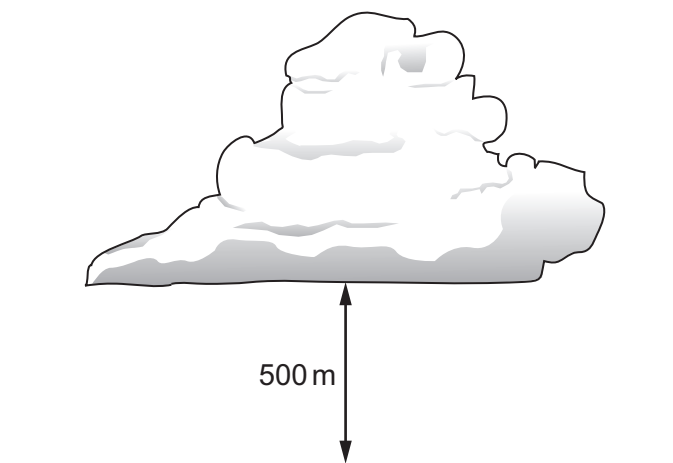

The potential difference between the base of the cloud and the ground is 200 MV. A raindrop with a charge of $4.0 \times 10^{-12} \text{ C}$ is in the region between the cloud and the ground.

What is the electrical force on the raindrop?

- A** $1.6 \times 10^{-6} \text{ N}$ **B** $8.0 \times 10^{-4} \text{ N}$ **C** $1.6 \times 10^{-3} \text{ N}$ **D** 0.40 N

32 The current I in a metal wire is given by the equation

$$I = Anvq.$$

What does the symbol n represent?

- A the number of charge carriers in the wire
 - B the number of charge carriers per unit cross-sectional area of the wire
 - C the number of charge carriers per unit length of the wire
 - D the number of charge carriers per unit volume of the wire
- 33 A cell of negligible internal resistance is connected to resistors R_1 , R_2 and R_3 , as shown. The cell provides power to the circuit and power is dissipated in the resistors.

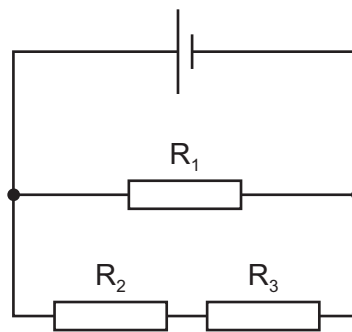

Which word equation **must** be correct?

- A power dissipated in R_1 = power dissipated in R_2 + power dissipated in R_3
- B power dissipated in R_2 = power dissipated in R_3
- C power output of cell = power dissipated in R_1 + power dissipated in R_2 + power dissipated in R_3
- D power output of cell = power dissipated in R_1

- 34 A fixed resistor and a diode are connected in series to a battery of electromotive force (e.m.f.) 6.0V and negligible internal resistance. The graph shows the variation with potential difference (p.d.) V of the current I for the diode.

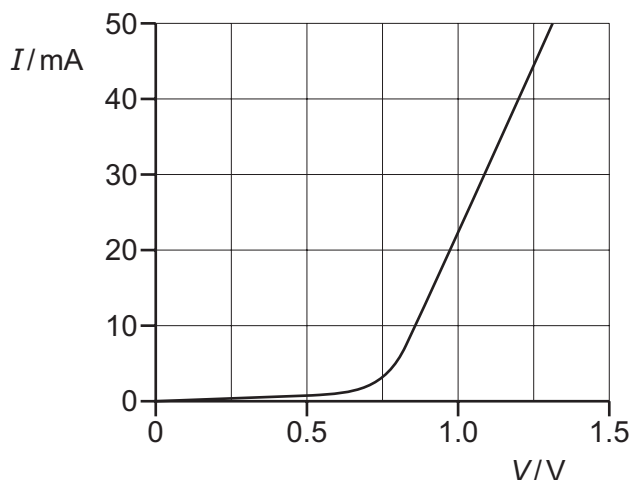
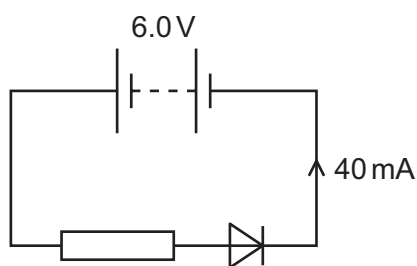

The current in the diode is 40 mA.

What is the resistance of the fixed resistor?

- A** $30\ \Omega$ **B** $120\ \Omega$ **C** $150\ \Omega$ **D** $180\ \Omega$
- 35 An electrical cable consists of seven strands of copper wire, each of diameter 0.30 mm, connected in parallel.

The resistivity of copper is $1.72 \times 10^{-8}\ \Omega\text{m}$. The current in the cable is 13 A.

What is the potential difference (p.d.) between two points on the cable a distance of 1.0 m apart?

- A** 0.0045 V **B** 0.11 V **C** 0.45 V **D** 3.2 V
- 36 A cell that has internal resistance is connected to a switch S and a variable resistor. A voltmeter is connected between the terminals of the cell, as shown.

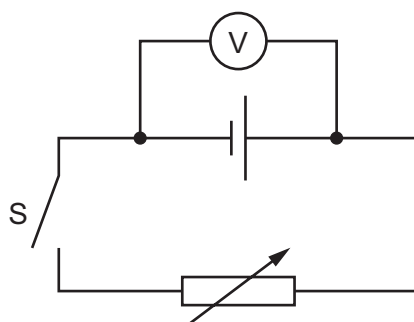

When switch S is open, the voltmeter reads 1.5 V. The switch is then closed and the variable resistor is adjusted to have a resistance of $4.0\ \Omega$. The voltmeter now reads 0.75 V.

What is the internal resistance of the cell?

- A** $1.0\ \Omega$ **B** $2.0\ \Omega$ **C** $4.0\ \Omega$ **D** $8.0\ \Omega$

- 37 A cell of electromotive force (e.m.f.) E and negligible internal resistance is connected into a circuit, as shown.

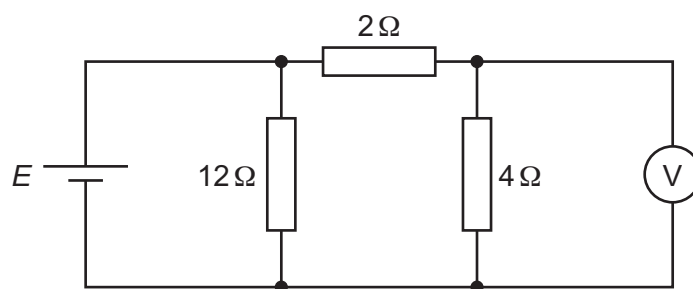

The voltmeter has a very high resistance and reads a potential difference V_{out} .

What is the ratio $\frac{V_{\text{out}}}{E}$?

- A $\frac{1}{6}$ B $\frac{1}{3}$ C $\frac{1}{2}$ D $\frac{2}{3}$
- 38 A battery is connected to a potentiometer. The potentiometer consists of a uniform resistance wire and a sliding contact P.

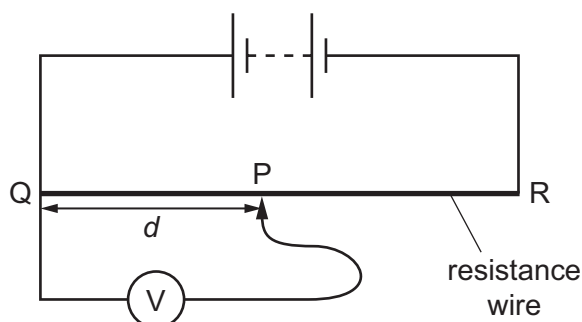

The potential difference (p.d.) V between the sliding contact P and end Q of the wire is measured using a voltmeter. The sliding contact P is moved from end Q to end R of the wire. Sliding contact P is distance d from Q.

Which graph shows the variation with distance d of the p.d. V ?

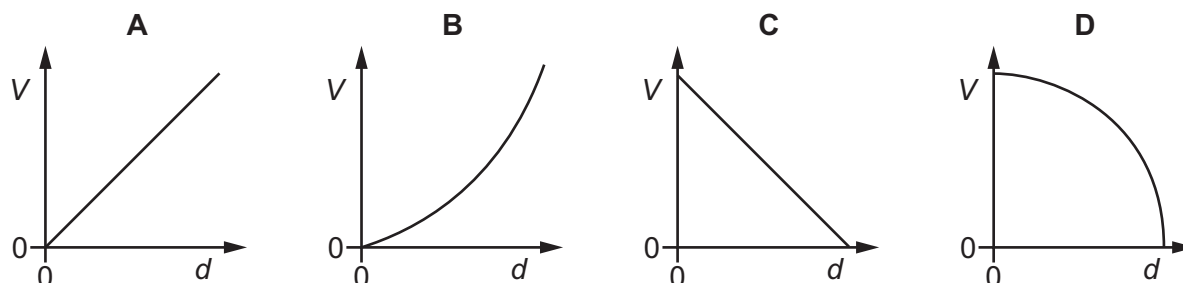

- 39 The figure shows part of a chart of nuclides where neutron number is plotted against proton number.

An unstable nuclide X decays by emitting an α -particle.

Which nuclide is formed by the decay of nuclide X?

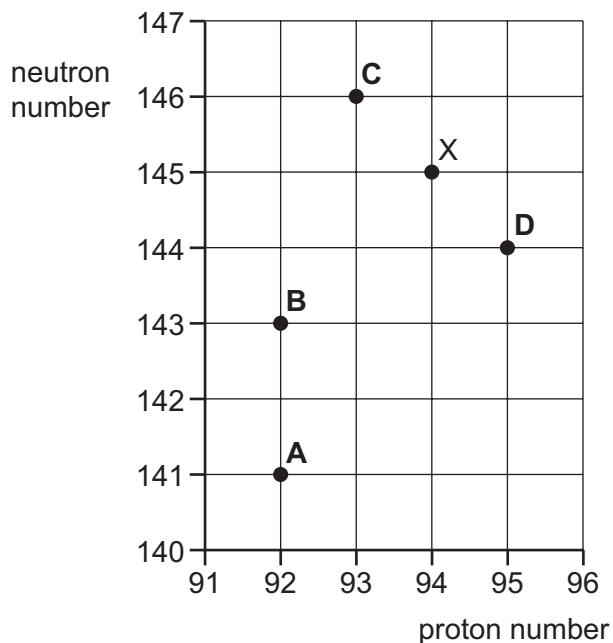

- 40 The nuclei of common isotopes of hydrogen, helium, lithium and beryllium are shown.

Which nucleus contains equal numbers of up and down quarks?

- A ${}^1_1\text{H}$ B ${}^4_2\text{He}$ C ${}^7_3\text{Li}$ D ${}^9_4\text{Be}$

BLANK PAGE

Permission to reproduce items where third-party owned material protected by copyright is included has been sought and cleared where possible. Every reasonable effort has been made by the publisher (UCLES) to trace copyright holders, but if any items requiring clearance have unwittingly been included, the publisher will be pleased to make amends at the earliest possible opportunity.

To avoid the issue of disclosure of answer-related information to candidates, all copyright acknowledgements are reproduced online in the Cambridge Assessment International Education Copyright Acknowledgements Booklet. This is produced for each series of examinations and is freely available to download at www.cambridgeinternational.org after the live examination series.

Cambridge Assessment International Education is part of the Cambridge Assessment Group. Cambridge Assessment is the brand name of the University of Cambridge Local Examinations Syndicate (UCLES), which itself is a department of the University of Cambridge.