



# Cambridge International AS & A Level

CANDIDATE  
NAME

--

CENTRE  
NUMBER

--	--	--	--	--

CANDIDATE  
NUMBER

--	--	--	--



## PHYSICS

9702/23

Paper 2 AS Level Structured Questions

May/June 2021

1 hour 15 minutes

You must answer on the question paper.

No additional materials are needed.

## INSTRUCTIONS

- Answer **all** questions.
- Use a black or dark blue pen. You may use an HB pencil for any diagrams or graphs.
- Write your name, centre number and candidate number in the boxes at the top of the page.
- Write your answer to each question in the space provided.
- Do **not** use an erasable pen or correction fluid.
- Do **not** write on any bar codes.
- You may use a calculator.
- You should show all your working and use appropriate units.

## INFORMATION

- The total mark for this paper is 60.
- The number of marks for each question or part question is shown in brackets [ ].

This document has **16** pages. Any blank pages are indicated.

**Data**

speed of light in free space	$c = 3.00 \times 10^8 \text{ m s}^{-1}$
permeability of free space	$\mu_0 = 4\pi \times 10^{-7} \text{ H m}^{-1}$
permittivity of free space	$\epsilon_0 = 8.85 \times 10^{-12} \text{ F m}^{-1}$
	$(\frac{1}{4\pi\epsilon_0} = 8.99 \times 10^9 \text{ m F}^{-1})$
elementary charge	$e = 1.60 \times 10^{-19} \text{ C}$
the Planck constant	$h = 6.63 \times 10^{-34} \text{ J s}$
unified atomic mass unit	$1 \text{ u} = 1.66 \times 10^{-27} \text{ kg}$
rest mass of electron	$m_e = 9.11 \times 10^{-31} \text{ kg}$
rest mass of proton	$m_p = 1.67 \times 10^{-27} \text{ kg}$
molar gas constant	$R = 8.31 \text{ J K}^{-1} \text{ mol}^{-1}$
the Avogadro constant	$N_A = 6.02 \times 10^{23} \text{ mol}^{-1}$
the Boltzmann constant	$k = 1.38 \times 10^{-23} \text{ J K}^{-1}$
gravitational constant	$G = 6.67 \times 10^{-11} \text{ N m}^2 \text{ kg}^{-2}$
acceleration of free fall	$g = 9.81 \text{ m s}^{-2}$

**Formulae**

uniformly accelerated motion	$s = ut + \frac{1}{2}at^2$ $v^2 = u^2 + 2as$
work done on/by a gas	$W = p\Delta V$
gravitational potential	$\phi = -\frac{Gm}{r}$
hydrostatic pressure	$p = \rho gh$
pressure of an ideal gas	$p = \frac{1}{3} \frac{Nm}{V} \langle c^2 \rangle$
simple harmonic motion	$a = -\omega^2 x$
velocity of particle in s.h.m.	$v = v_0 \cos \omega t$ $v = \pm \omega \sqrt{(x_0^2 - x^2)}$
Doppler effect	$f_o = \frac{f_s v}{v \pm v_s}$
electric potential	$V = \frac{Q}{4\pi\epsilon_0 r}$
capacitors in series	$1/C = 1/C_1 + 1/C_2 + \dots$
capacitors in parallel	$C = C_1 + C_2 + \dots$
energy of charged capacitor	$W = \frac{1}{2} QV$
electric current	$I = Anvq$
resistors in series	$R = R_1 + R_2 + \dots$
resistors in parallel	$1/R = 1/R_1 + 1/R_2 + \dots$
Hall voltage	$V_H = \frac{BI}{ntq}$
alternating current/voltage	$x = x_0 \sin \omega t$
radioactive decay	$x = x_0 \exp(-\lambda t)$
decay constant	$\lambda = \frac{0.693}{t_{\frac{1}{2}}}$

Answer **all** the questions in the spaces provided.

- 1 (a) A property of a vector quantity, that is not a property of a scalar quantity, is direction. For example, velocity has direction but speed does not.

- (i) State **two** other scalar quantities and **two** other vector quantities.

scalar quantities: ..... and .....

vector quantities: ..... and ..... [2]

- (ii) State **two** properties that are possessed by both scalar and vector physical quantities.

1. ....

2. .... [2]

- (b) A ship at sea is travelling with a velocity of  $13 \text{ m s}^{-1}$  in a direction  $35^\circ$  east of north in still water, as shown in Fig. 1.1.

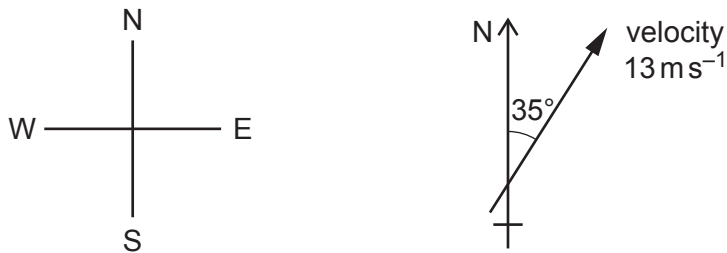

**Fig. 1.1**

- (i) Determine the magnitudes of the components of the velocity of the ship in the north and the east directions.

north component of velocity = .....  $\text{m s}^{-1}$

east component of velocity = .....  $\text{m s}^{-1}$  [2]

- (ii) The ship now experiences a tidal current. The water in the sea moves with a velocity of  $2.7 \text{ m s}^{-1}$  to the west.

Calculate the resultant velocity component of the ship in the east direction.

resultant east component of velocity = .....  $\text{m s}^{-1}$  [1]

- (iii) Use your answers in (b)(i) and (b)(ii) to determine the magnitude of the resultant velocity of the ship.

magnitude of resultant velocity = .....  $\text{m s}^{-1}$  [2]

- (iv) Use your answers in (b)(i) and (b)(ii) to determine the angle between north and the resultant velocity of the ship.

angle = ..... $^{\circ}$  [2]

[Total: 11]

2 (a) Define *acceleration*.

.....  
 ..... [1]

(b) A stone falls vertically from the top of a cliff. Fig. 2.1 shows the variation with time  $t$  of the velocity  $v$  of the stone.

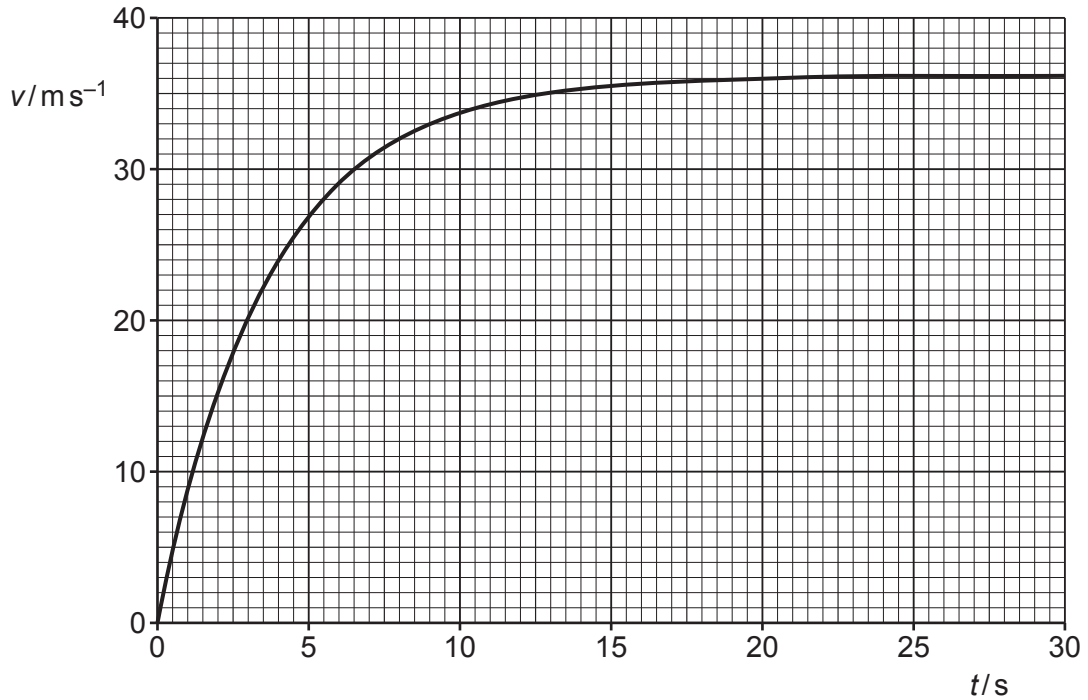

**Fig. 2.1**

(i) Explain, with reference to forces acting on the stone, the shape of the curve in Fig. 2.1.

.....  
 .....  
 .....  
 .....  
 ..... [3]

(ii) Use Fig. 2.1 to determine the speed of the stone when the resultant force on it is zero.

speed = .....  $\text{ms}^{-1}$  [1]

- (iii) Use Fig. 2.1 to calculate the approximate height through which the stone falls between  $t = 0$  and  $t = 30$  s.

height = ..... m [3]

- (iv) On Fig. 2.2, sketch the variation with  $t$  of the acceleration  $a$  of the stone between  $t = 0$  and  $t = 30$  s.

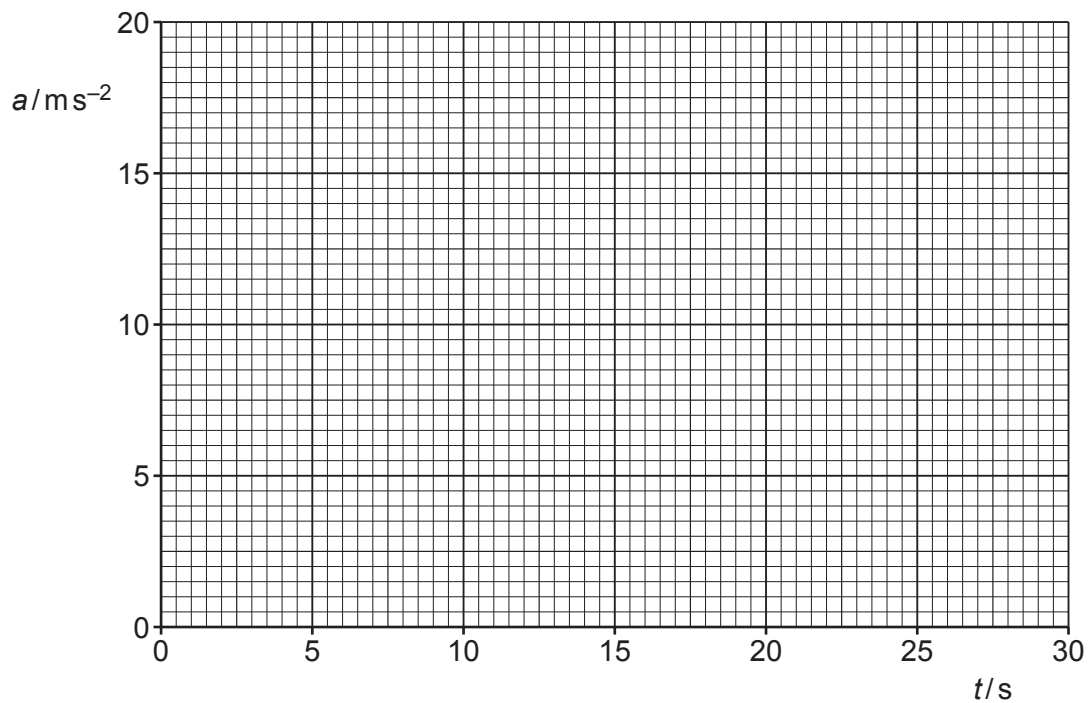

**Fig. 2.2**

[3]

[Total: 11]

- 3 (a) Define the *moment* of a force about a point.

.....

.....

..... [2]

- (b) Fig. 3.1 shows a type of balance that is used for measuring mass.

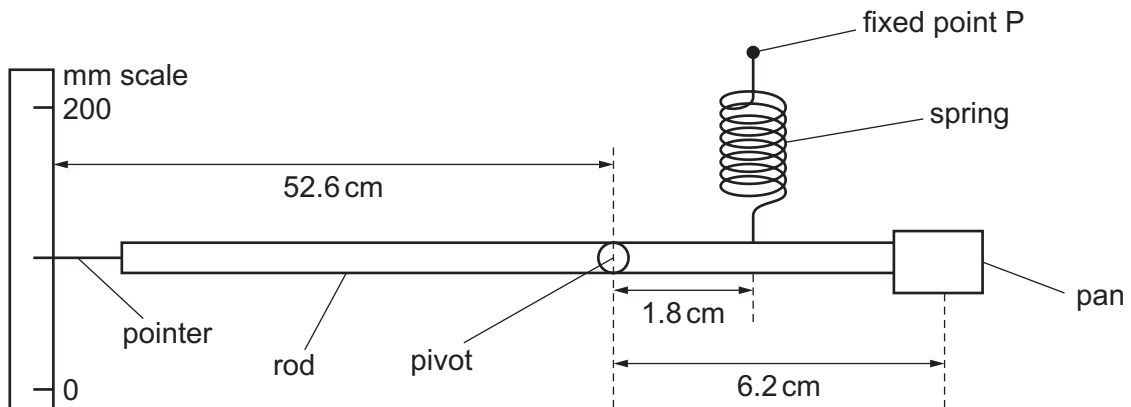

**Fig. 3.1** (not to scale)

A rigid rod is pivoted about a point 6.2 cm from the centre of a pan which is attached to one end. The object being measured is placed on the centre of this pan.

A spring, attached to the rod 1.8 cm from the pivot, is attached at its other end to a fixed point P. The spring obeys Hooke's law over the full range of operation of the balance.

A pointer, on the other side of the pivot, is set against a millimetre scale which is a distance 52.6 cm from the pivot.

When the system is in equilibrium with no mass on the pan, the rod is horizontal and the pointer indicates a reading on the scale of 86 mm.

An object of mass 0.472 kg is now placed on the pan. As a result, the pointer moves to indicate a reading of 123 mm on the scale when the system is again in equilibrium.

- (i) Show that the increase in the length of the spring is approximately 1.3 mm.

[2]



- (ii) Calculate the magnitude of the moment about the pivot of the weight of the object.

moment = ..... Nm [2]

- (iii) Use your answer in **(b)(ii)** to determine the increase in the tension in the spring due to the 0.472 kg mass.

increase in tension = ..... N [2]

- (iv) Use the information in **(b)(i)** and your answer in **(b)(iii)** to determine the spring constant  $k$  of the spring. Give a unit with your answer.

$k$  = ..... unit ..... [2]

[Total: 10]

- 4 (a) State the principle of superposition.

.....

.....

..... [2]

- (b) Two waves, with intensities  $I$  and  $4I$ , superpose. The waves have the same frequency.

Determine, in terms of  $I$ , the maximum possible intensity of the resulting wave.

maximum intensity = .....  $I$  [2]

- (c) Coherent light of wavelength  $550\text{ nm}$  is incident normally on a double slit of slit separation  $0.35\text{ mm}$ . A series of bright and dark fringes forms on a screen placed a distance of  $1.2\text{ m}$  from the double slit, as shown in Fig. 4.1. The screen is parallel to the double slit.

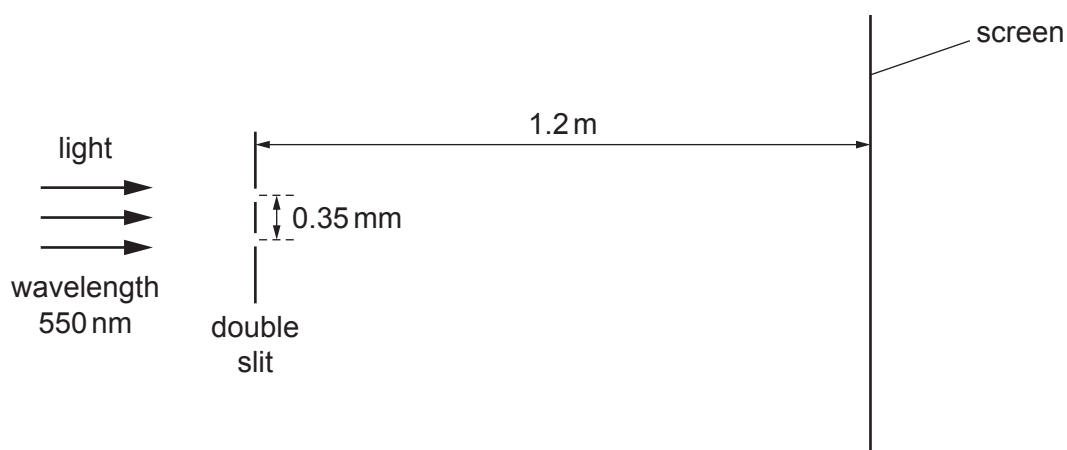

Fig. 4.1 (not to scale)

- (i) Determine the distance between the centres of adjacent bright fringes on the screen.

distance = ..... m [3]

- (ii) The light of wavelength 550 nm is replaced with red light of a single frequency.

State and explain the change, if any, in the distance between the centres of adjacent bright fringes.

.....  
.....  
..... [1]

[Total: 8]

- 5 (a) Define the *electromotive force (e.m.f.)* of a source.

.....

.....

..... [2]

- (b) The circuit shown in Fig. 5.1 contains a battery of e.m.f.  $E$  that has internal resistance  $r$ , a variable resistor, a voltmeter and an ammeter.

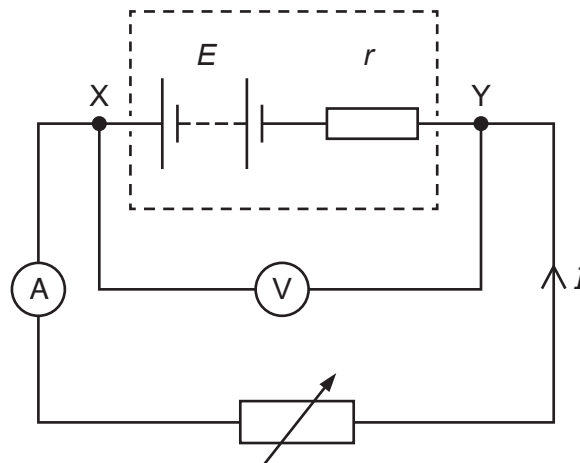

Fig. 5.1

Readings from the two meters are taken for different settings of the variable resistor. The variation with current  $I$  of the potential difference (p.d.)  $V$  across the terminals XY of the battery is shown in Fig. 5.2.

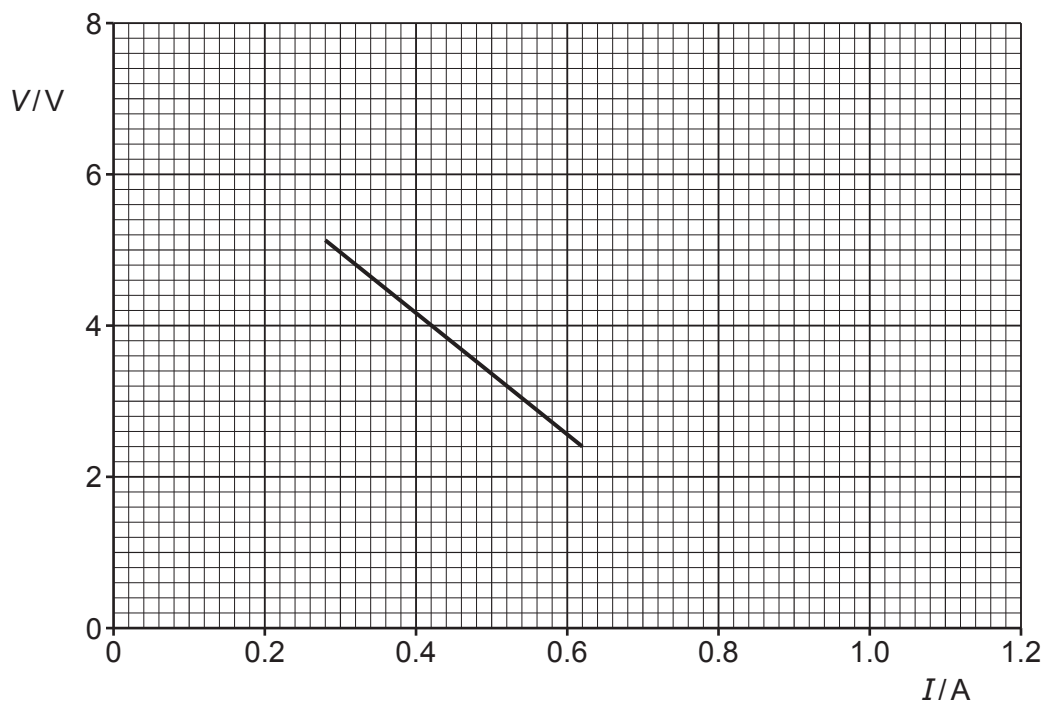

Fig. 5.2

Explain why  $V$  is not constant.

.....

.....

.....

..... [3]

(c) For the battery in (b), use Fig. 5.2 to determine:

(i) the e.m.f.  $E$

$$E = \dots\dots\dots \text{ V [1]}$$

(ii) the maximum current that the battery can supply

$$\text{maximum current} = \dots\dots\dots \text{ A [1]}$$

(iii) the internal resistance  $r$ .

$$r = \dots\dots\dots \Omega [2]$$

(d) On Fig. 5.2, sketch a line to show a possible variation with  $I$  of  $V$  for a battery with a lower e.m.f. and a lower internal resistance than the battery in (b). Your line should extend over at least the same range of currents as the original line. [2]

[Total: 11]

6 (a) State the quark composition of:

(i) a proton

..... [1]

(ii) a neutron

..... [1]

(iii) an alpha-particle.

.....  
..... [2]

(b) In the alpha-particle scattering experiment, alpha-particles were directed at a thin gold foil.

State what may be inferred from:

(i) the observation that most alpha-particles pass through the foil

..... [1]

(ii) the observation that some alpha-particles are scattered through angles greater than 90°.

.....  
.....  
..... [2]

(c) A proton and an alpha-particle are moving in the same uniform electric field.

Determine the ratio

$$\frac{\text{acceleration of proton due to the electric field}}{\text{acceleration of alpha-particle due to the electric field}}$$

ratio = ..... [2]

[Total: 9]



**BLANK PAGE**

---

Permission to reproduce items where third-party owned material protected by copyright is included has been sought and cleared where possible. Every reasonable effort has been made by the publisher (UCLES) to trace copyright holders, but if any items requiring clearance have unwittingly been included, the publisher will be pleased to make amends at the earliest possible opportunity.

To avoid the issue of disclosure of answer-related information to candidates, all copyright acknowledgements are reproduced online in the Cambridge Assessment International Education Copyright Acknowledgements Booklet. This is produced for each series of examinations and is freely available to download at [www.cambridgeinternational.org](http://www.cambridgeinternational.org) after the live examination series.

Cambridge Assessment International Education is part of the Cambridge Assessment Group. Cambridge Assessment is the brand name of the University of Cambridge Local Examinations Syndicate (UCLES), which itself is a department of the University of Cambridge.