



# Cambridge International AS & A Level

---

## PHYSICS

9702/11

Paper 1 Multiple Choice

May/June 2021

1 hour 15 minutes

You must answer on the multiple choice answer sheet.

You will need: Multiple choice answer sheet  
Soft clean eraser  
Soft pencil (type B or HB is recommended)

---

## INSTRUCTIONS

- There are **forty** questions on this paper. Answer **all** questions.
- For each question there are four possible answers **A**, **B**, **C** and **D**. Choose the **one** you consider correct and record your choice in soft pencil on the multiple choice answer sheet.
- Follow the instructions on the multiple choice answer sheet.
- Write in soft pencil.
- Write your name, centre number and candidate number on the multiple choice answer sheet in the spaces provided unless this has been done for you.
- Do **not** use correction fluid.
- Do **not** write on any bar codes.
- You may use a calculator.

## INFORMATION

- The total mark for this paper is 40.
- Each correct answer will score one mark.
- Any rough working should be done on this question paper.

---

This document has **20** pages.



**Data**

speed of light in free space	$c = 3.00 \times 10^8 \text{ m s}^{-1}$
permeability of free space	$\mu_0 = 4\pi \times 10^{-7} \text{ H m}^{-1}$
permittivity of free space	$\epsilon_0 = 8.85 \times 10^{-12} \text{ F m}^{-1}$ $(\frac{1}{4\pi\epsilon_0} = 8.99 \times 10^9 \text{ m F}^{-1})$
elementary charge	$e = 1.60 \times 10^{-19} \text{ C}$
the Planck constant	$h = 6.63 \times 10^{-34} \text{ J s}$
unified atomic mass unit	$1 \text{ u} = 1.66 \times 10^{-27} \text{ kg}$
rest mass of electron	$m_e = 9.11 \times 10^{-31} \text{ kg}$
rest mass of proton	$m_p = 1.67 \times 10^{-27} \text{ kg}$
molar gas constant	$R = 8.31 \text{ J K}^{-1} \text{ mol}^{-1}$
the Avogadro constant	$N_A = 6.02 \times 10^{23} \text{ mol}^{-1}$
the Boltzmann constant	$k = 1.38 \times 10^{-23} \text{ J K}^{-1}$
gravitational constant	$G = 6.67 \times 10^{-11} \text{ N m}^2 \text{ kg}^{-2}$
acceleration of free fall	$g = 9.81 \text{ m s}^{-2}$

**Formulae**

uniformly accelerated motion	$s = ut + \frac{1}{2}at^2$ $v^2 = u^2 + 2as$
work done on/by a gas	$W = p\Delta V$
gravitational potential	$\phi = -\frac{Gm}{r}$
hydrostatic pressure	$p = \rho gh$
pressure of an ideal gas	$p = \frac{1}{3} \frac{Nm}{V} \langle c^2 \rangle$
simple harmonic motion	$a = -\omega^2 x$
velocity of particle in s.h.m.	$v = v_0 \cos \omega t$ $v = \pm \omega \sqrt{(x_0^2 - x^2)}$
Doppler effect	$f_o = \frac{f_s v}{v \pm v_s}$
electric potential	$V = \frac{Q}{4\pi\epsilon_0 r}$
capacitors in series	$1/C = 1/C_1 + 1/C_2 + \dots$
capacitors in parallel	$C = C_1 + C_2 + \dots$
energy of charged capacitor	$W = \frac{1}{2}QV$
electric current	$I = Anvq$
resistors in series	$R = R_1 + R_2 + \dots$
resistors in parallel	$1/R = 1/R_1 + 1/R_2 + \dots$
Hall voltage	$V_H = \frac{BI}{ntq}$
alternating current/voltage	$x = x_0 \sin \omega t$
radioactive decay	$x = x_0 \exp(-\lambda t)$
decay constant	$\lambda = \frac{0.693}{t_{\frac{1}{2}}}$

- 1 What is a reasonable estimate of the volume of an adult person?  
**A**  $0.10 \text{ m}^3$       **B**  $0.50 \text{ m}^3$       **C**  $1.0 \text{ m}^3$       **D**  $2.0 \text{ m}^3$
- 2 Which combination of units could be used for expressing the power dissipated in a resistor?  
**A** newton per second ( $\text{N s}^{-1}$ )  
**B** newton second ( $\text{Ns}$ )  
**C** newton metre ( $\text{Nm}$ )  
**D** newton metre per second ( $\text{Nm s}^{-1}$ )
- 3 A force of 10 N and a force of 5 N act on an object.

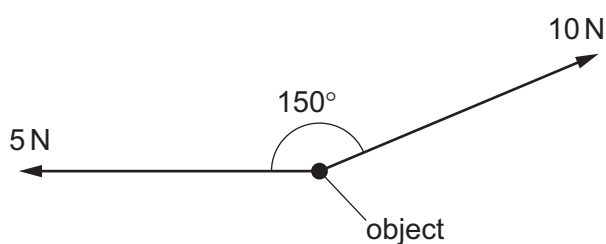

The angle between the forces is  $150^\circ$ .

The resultant force on the object can be resolved into a pair of perpendicular components.

Which row shows numerical expressions for a possible pair of perpendicular components?

	force component / N	force component / N
<b>A</b>	$10 \cos 30^\circ - 5$	$10 \cos 30^\circ$
<b>B</b>	$10 \sin 30^\circ - 5$	$10 \cos 30^\circ$
<b>C</b>	$10 - 5 \cos 30^\circ$	$5 \sin 30^\circ$
<b>D</b>	$10 - 5 \sin 30^\circ$	$5 \cos 30^\circ$

- 4 A signal of frequency 25 Hz is displayed on the screen of a cathode-ray oscilloscope.

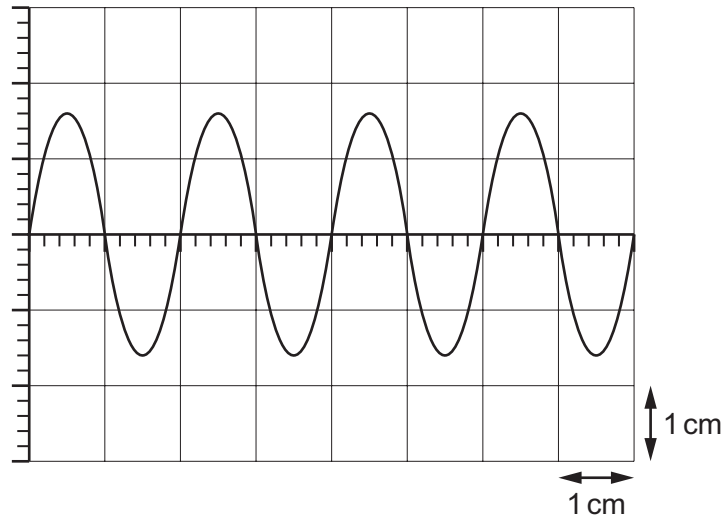

What is the time-base setting?

- A**  $10 \text{ ms cm}^{-1}$     **B**  $20 \text{ ms cm}^{-1}$     **C**  $25 \text{ ms cm}^{-1}$     **D**  $40 \text{ ms cm}^{-1}$
- 5 A micrometer screw gauge is used to measure the diameter of a wire.
- The reading on the micrometer with the jaws closed is  $(-0.05 \pm 0.02) \text{ mm}$ .
- The reading with the wire in position between the two jaws is  $(+1.03 \pm 0.02) \text{ mm}$ .

What is the diameter of the wire?

- A**  $(0.98 \pm 0.02) \text{ mm}$
- B**  $(1.08 \pm 0.02) \text{ mm}$
- C**  $(0.98 \pm 0.04) \text{ mm}$
- D**  $(1.08 \pm 0.04) \text{ mm}$

- 6 A projectile is launched at an angle to the horizontal at time  $t = 0$ . It travels over horizontal ground, as shown.

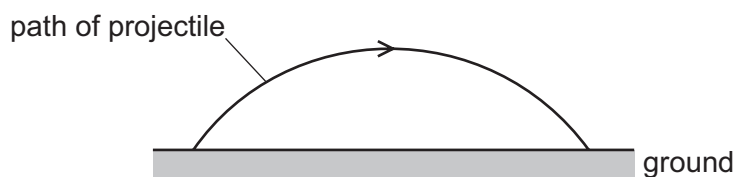

Air resistance is negligible.

Which graph best shows the variation with  $t$  of the speed of the projectile from when it is launched to when it lands on the ground?

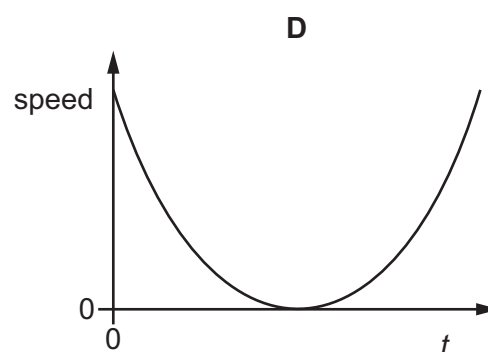
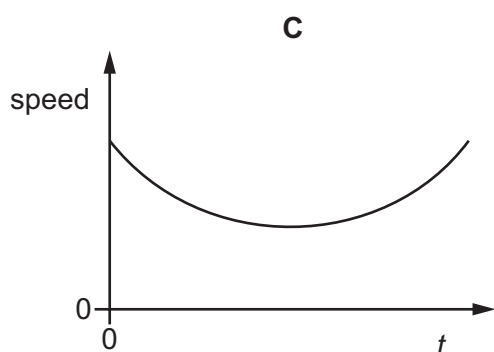
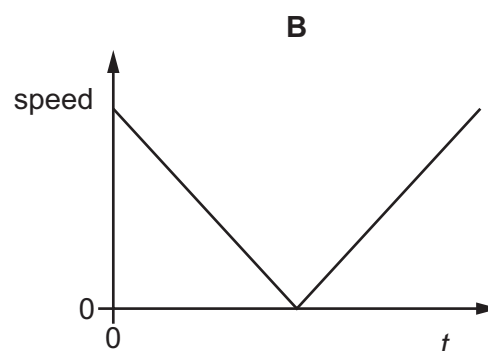
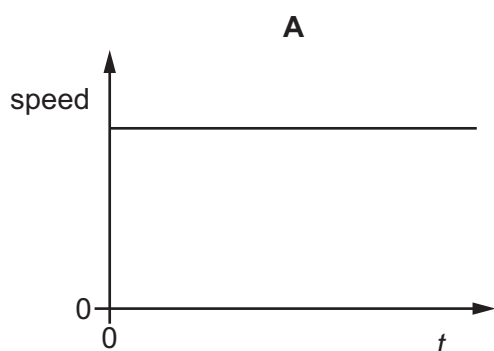

- 7 A train, initially at rest at a station, has a uniform acceleration of  $0.20 \text{ ms}^{-2}$  until it reaches a speed of  $20 \text{ ms}^{-1}$ . It travels for a time at this constant speed and then has a uniform deceleration of  $0.40 \text{ ms}^{-2}$  until it comes to rest at the next station. The distance between the two stations is 3000 m.

What is the time taken by the train to travel between the two stations?

- A** 75s      **B** 150s      **C** 230s      **D** 300s

- 8 A rocket is fired from the Earth into space.

Newton's third law of motion describes how forces act in pairs. One of the forces of a pair is the weight of the rocket.

What is the other force of this pair?

- A** air resistance  
**B** force of the exhaust gases on the rocket  
**C** force of the rocket on the exhaust gases  
**D** gravitational force of the rocket on the Earth
- 9 The graph shows how quantity  $P$  varies with quantity  $Q$  for a body falling vertically downwards in a uniform gravitational field with air resistance.

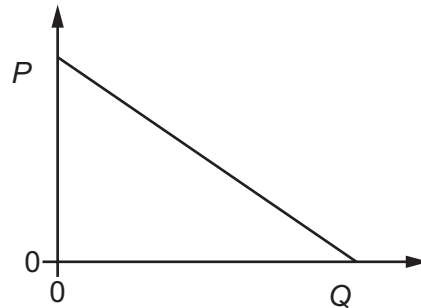

Which pair of quantities could be represented by  $P$  and  $Q$ ?

	$P$	$Q$
<b>A</b>	acceleration	force of air resistance
<b>B</b>	acceleration	time
<b>C</b>	velocity	force of air resistance
<b>D</b>	velocity	time

- 10 Which quantities are conserved in an inelastic collision?

	kinetic energy	total energy	linear momentum
<b>A</b>	conserved	not conserved	conserved
<b>B</b>	conserved	not conserved	not conserved
<b>C</b>	not conserved	conserved	conserved
<b>D</b>	not conserved	conserved	not conserved

11 A charged oil drop is held stationary between two charged parallel plates.

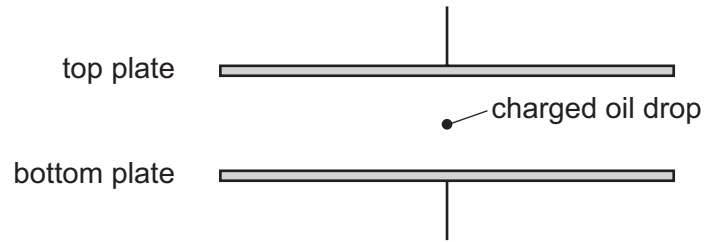

Which forces act on the oil drop?

- A both electric and gravitational
- B electric only
- C gravitational only
- D neither electric nor gravitational

12 Which pair of forces forms a couple with a torque of  $30 \text{ N m}$ ?

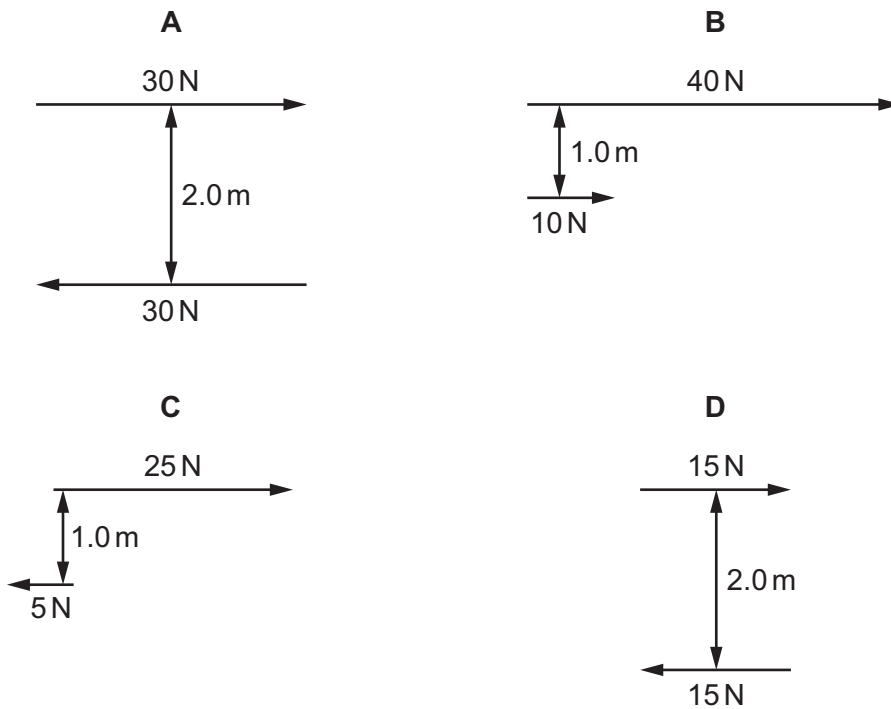



- 13** A uniform rigid bar XZ with negligible mass is 1.20 m long. The bar is pivoted at point P. Three coplanar forces act on the bar as shown. Forces of 16 N and 20 N act perpendicularly to the bar at points X and Y respectively. Force  $F$  acts at point Z at an angle of  $30^\circ$  to the axis of the bar.

The distances along the bar of the pivot and of the forces are shown.

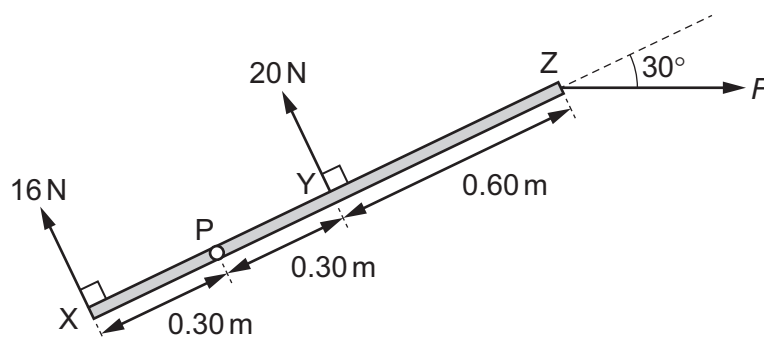

The bar experiences a resultant moment about P of 6.0 N m in a clockwise direction.

What is the magnitude of  $F$ ?

- A** 9.2 N      **B** 11 N      **C** 16 N      **D** 24 N
- 14** Water of depth 9.0 cm is covered by oil of depth 5.0 cm in a measuring cylinder. The density of the water is  $1000 \text{ kg m}^{-3}$  and the density of the oil is  $800 \text{ kg m}^{-3}$ . What is the total pressure exerted on the base of the measuring cylinder due to the oil and water?
- A** 390 Pa      **B** 880 Pa      **C** 1200 Pa      **D** 1300 Pa
- 15** A rocket is fired upwards. As it accelerates upwards after leaving the launch pad, which forms of energy are changing?
- A** chemical energy, gravitational potential energy and kinetic energy  
**B** chemical energy and gravitational potential energy only  
**C** chemical energy and kinetic energy only  
**D** gravitational potential energy and kinetic energy only
- 16** A roll of tape of length 50 m requires a constant force of 20 N to unwrap it.

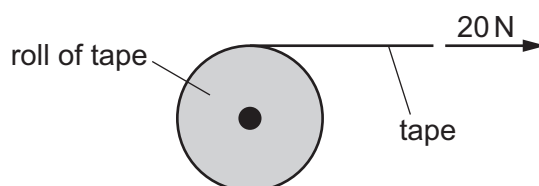

What is the work done in unwrapping the whole roll?

- A** 0.4 J      **B** 2.5 J      **C** 500 J      **D** 1000 J

- 17 A trolley of mass 600 kg is initially at point P on a slope, at a height of 80 m above ground level, as shown. The trolley is released from rest and moves along the slope, first coming to rest at point Q, at height  $h$  above ground level.

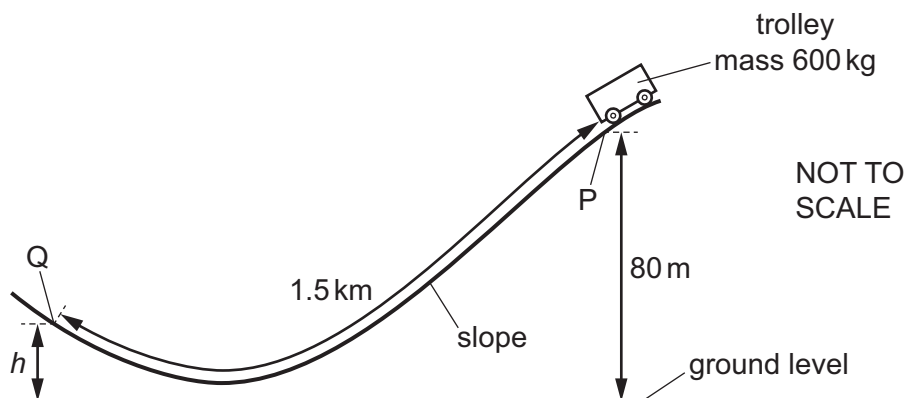

The total distance PQ moved by the trolley along the slope is 1.5 km. A constant resistive force of 300 N opposes the motion of the trolley on the slope.

What is  $h$ ?

- A 3.5 m                      B 76 m                      C 79 m                      D 80 m
- 18 An object of weight 15.0 N is pulled along a horizontal surface at a constant velocity of  $2.00 \text{ m s}^{-1}$ . The force pulling the object is 12.0 N at  $30.0^\circ$  to the horizontal, as shown.

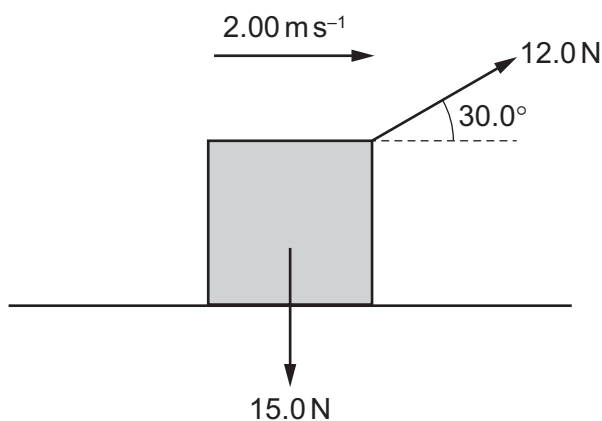

What is the power used to move the object?

- A 12.0 W                      B 20.8 W                      C 24.0 W                      D 30.0 W

- 19 The spring constants of four springs are determined by plotting the following graphs of force  $F$  against extension  $x$ .

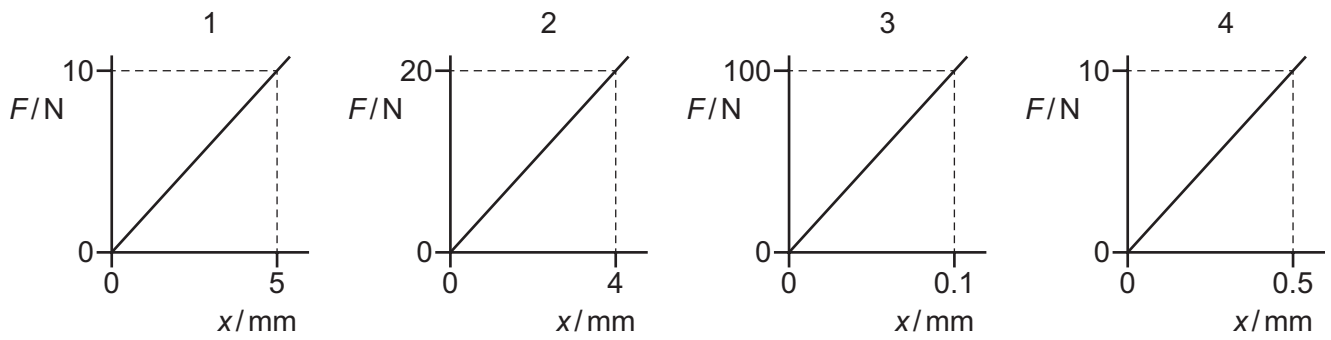

Which order of the graphs shows **decreasing** spring constants?

- A 2 → 1 → 3 → 4
- B 3 → 4 → 2 → 1
- C 4 → 2 → 1 → 3
- D 4 → 3 → 2 → 1

- 20 Forces are applied to the ends of a rod so that its length increases. The variation with force  $F$  of the extension  $e$  of the rod is shown.

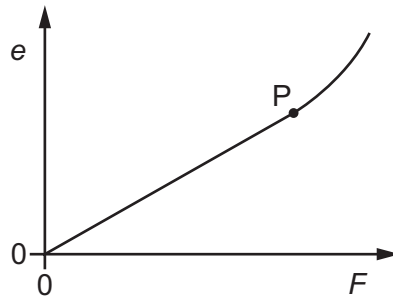

The point P is the elastic limit.

Which shaded area represents the work done during the plastic deformation of the rod?

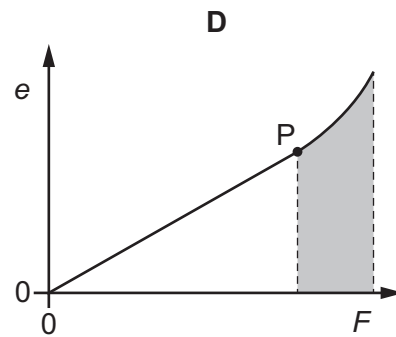
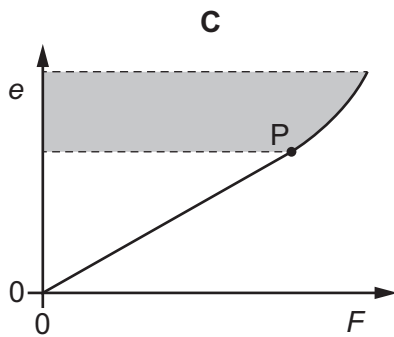
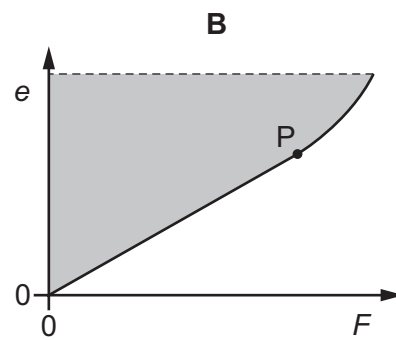
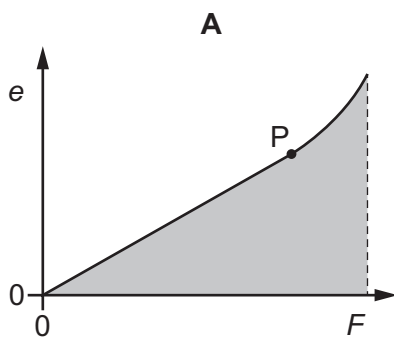

- 21 Two identical waves are produced by sources at points P and Q. The waves travel along different paths to reach point R, as shown.

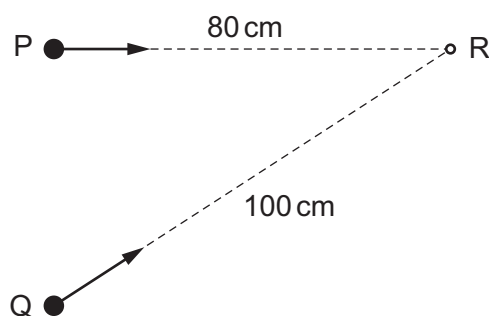

Both waves have a wavelength of 6.0 cm. The waves are in phase at point R.

What is the phase difference between the waves as they leave points P and Q?

- A  $0^\circ$                       B  $60^\circ$                       C  $90^\circ$                       D  $120^\circ$
- 22 A longitudinal wave travelling from left to right has vibrations parallel to the direction of transfer of energy by the wave.

The wave can be represented on a graph showing the variation with distance of the displacement of the particles from their equilibrium positions at one instant.

Which point on the graph is the centre of a compression?

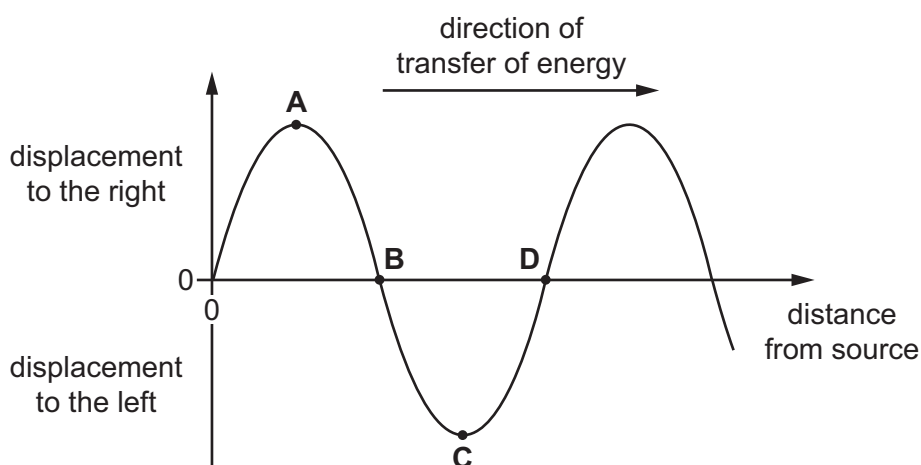

- 23 A stationary wave is formed from two identical sound waves.

A microphone is placed at a position of maximum loudness. It is then moved along the stationary wave from this first position of maximum loudness to the fourth position of maximum loudness. The microphone moves a distance of 12 cm.

The speed of sound is  $330 \text{ m s}^{-1}$ .

What is the frequency of the sound waves?

- A 4100 Hz                      B 5500 Hz                      C 8300 Hz                      D 11 000 Hz

- 24** An ambulance has a siren that emits sound of a constant frequency. The ambulance is moving directly towards a stationary observer.

The ambulance decelerates as it is approaching the observer and then accelerates after it has passed the observer.

How does the frequency of the sound heard by the observer change as the ambulance is approaching and as it is moving away from the observer?

	approaching observer	moving away from observer
<b>A</b>	decreases	decreases
<b>B</b>	decreases	increases
<b>C</b>	increases	decreases
<b>D</b>	increases	increases

- 25** Microwaves in a vacuum travel at speed  $X$  and have wavelength of order of magnitude  $Y$ .

What are the speed and a possible order of magnitude of wavelength of X-rays in a vacuum?

	speed	wavelength
<b>A</b>	$X$	$10^{-8} Y$
<b>B</b>	$X$	$10^{-4} Y$
<b>C</b>	$10^4 X$	$Y$
<b>D</b>	$10^8 X$	$Y$

26 The diagram shows part of a stationary wave on a string.

X and Y are points on the string. The vibrations at X and Y are  $180^\circ$  out of phase.

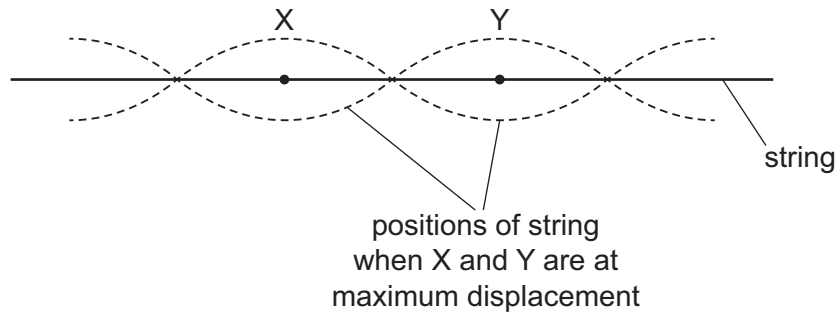

What is the distance between X and Y?

- A one-quarter of a wavelength
- B half a wavelength
- C one wavelength
- D two wavelengths

27 Which wave behaviour is shown in the diagram?

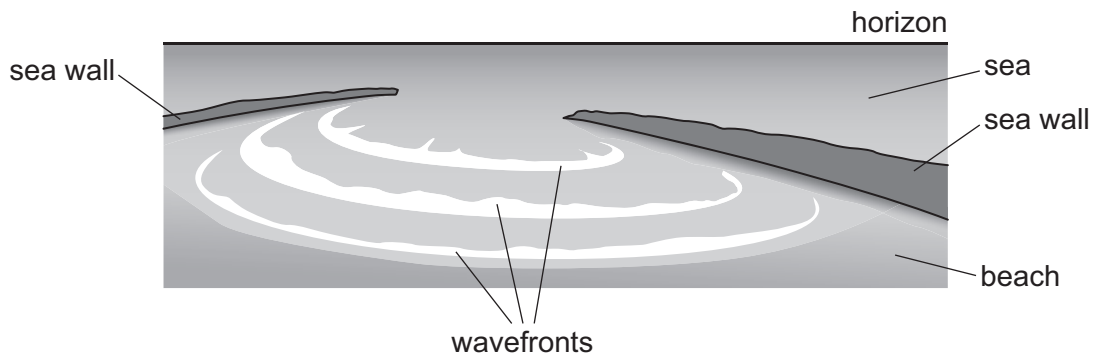

- A diffraction
- B Doppler shift
- C interference
- D superposition

- 28 A teacher sets up the apparatus shown to demonstrate a double-slit interference pattern on a screen.

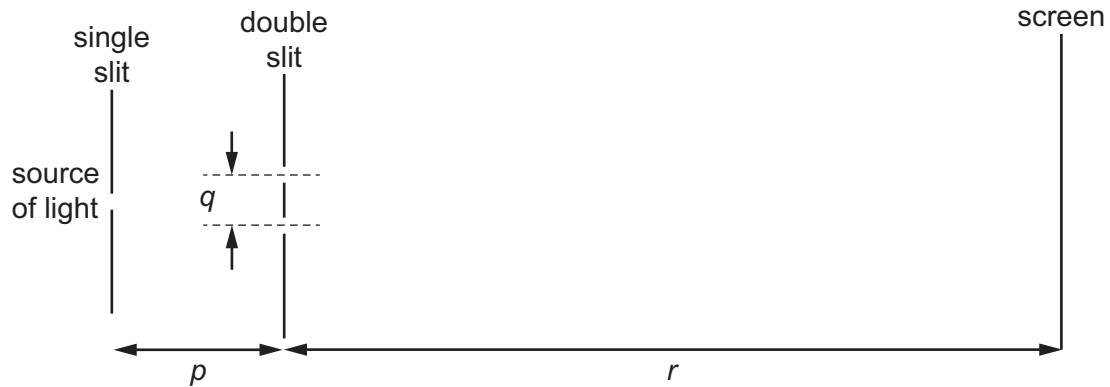

Which change to the apparatus will increase the fringe spacing?

- A** decrease the distance  $p$   
**B** decrease the distance  $q$   
**C** decrease the distance  $r$   
**D** decrease the wavelength of the light
- 29 Light of a single unknown wavelength and blue light of a single wavelength are both incident normally on a diffraction grating. Two diffraction patterns are produced, one for each wavelength of light.

The third-order maximum for the blue light occurs at the same angle as the second-order maximum for the light of unknown wavelength. The wavelength of the blue light is 480 nm.

What is the unknown wavelength?

- A** 320 nm      **B** 720 nm      **C** 960 nm      **D** 1440 nm
- 30 What is the electric field strength in a region where a proton accelerates at  $2.00 \text{ m s}^{-2}$  due to the field?
- A**  $11.4 \text{ pV m}^{-1}$       **B**  $5.22 \text{ nV m}^{-1}$       **C**  $10.4 \text{ nV m}^{-1}$       **D**  $20.9 \text{ nV m}^{-1}$



- 31 An oil drop of mass  $2.6 \times 10^{-15}$  kg and with a charge of  $-4.8 \times 10^{-19}$  C is in a vacuum between two horizontal plates. The plates have a separation of 2.0 cm and a potential difference (p.d.) between them of 1200 V, as shown.

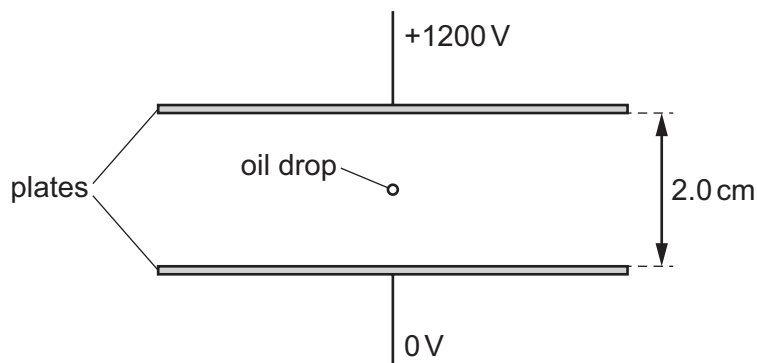

Which statement describes the motion of the oil drop?

- A It is stationary.  
 B It has a downward acceleration of  $9.7 \text{ m s}^{-2}$ .  
 C It has an upward acceleration of  $1.3 \text{ m s}^{-2}$ .  
 D It has an upward acceleration of  $11 \text{ m s}^{-2}$ .
- 32 Which two units are used to define the coulomb?
- A ampere and second  
 B ampere and volt  
 C volt and ohm  
 D volt and second
- 33 A mobile phone battery is charged by connecting it to a constant potential difference of 5.0 V. After a time of 1.0 hour, the initial current of 0.50 A slowly decreases to zero, as shown.

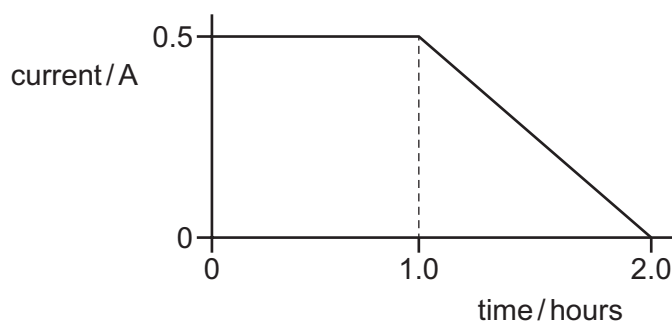

What is the best estimate of the energy transferred to the battery during the time of 2.0 hours shown in the graph?

- A 2700 J      B 9000 J      C 14 000 J      D 18 000 J

34 A length of wire is connected into an electric circuit. The current in the wire is measured.

Which change on its own could increase the current in the wire?

- A an increase in the length of the wire
- B an increase in the radius of the wire
- C an increase in the resistance of the wire
- D an increase in the resistivity of the wire

35 A cell is described as having an electromotive force (e.m.f.) of 6 V.

What does this mean?

- A 1 coulomb of charge always dissipates 6 J of energy in the internal resistance of the cell.
- B 1 electron gains 6 J of energy when passing through the cell.
- C There is a potential difference of 6 V applied across any external circuit connected to the cell.
- D When 1 coulomb of charge passes through the cell, 6 J of chemical energy is transformed.

36 The diagram shows a network of resistors. Each resistor has resistance  $R$ .

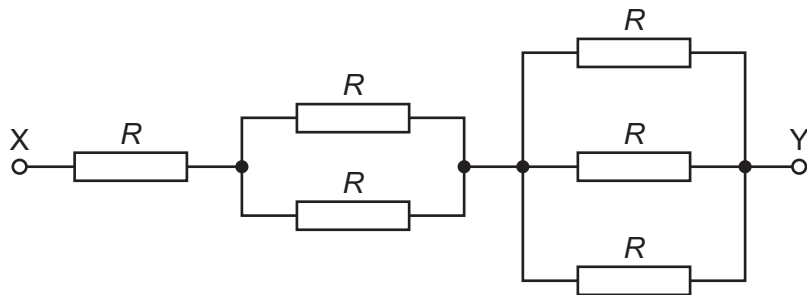

What is the total resistance of the network between points X and Y?

- A  $\frac{R}{6}$
- B  $\frac{6R}{11}$
- C  $\frac{11R}{6}$
- D  $6R$

- 37 Three resistors are connected in series with a battery, as shown. The battery has negligible internal resistance.

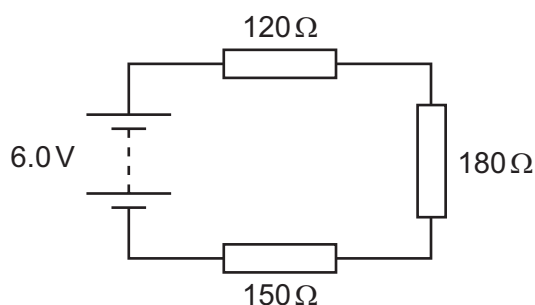

What is the potential difference across the  $180\Omega$  resistor?

- A 1.6V      B 2.4V      C 3.6V      D 4.0V
- 38 A potentiometer circuit is used to determine the unknown electromotive force (e.m.f.) of a cell X.
- In the circuit shown, E is a cell with an e.m.f. that is known accurately. QR is the potentiometer wire, which has a movable contact S. Contact S is connected to a galvanometer and to cell X.

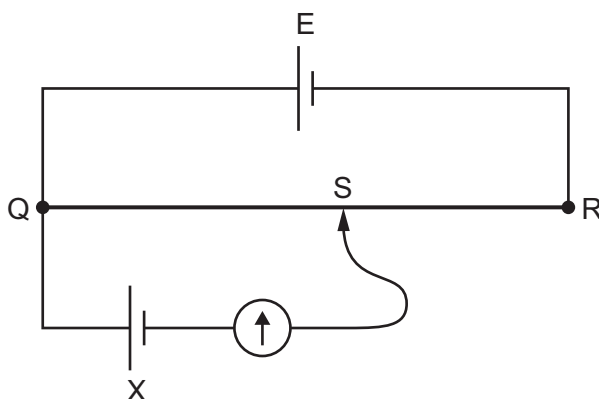

What is **not** a necessary requirement to determine the e.m.f. of X from the circuit?

- A The e.m.f. of cell X must be lower than the e.m.f. of cell E.  
 B The internal resistance of cell X must be known.  
 C The lengths QS and QR must be determined accurately.  
 D The resistance of the wire QR must be proportional to its length.
- 39 A nucleus of uranium,  ${}_{92}^{235}\text{U}$ , undergoes a series of decays. During the series of decays, two  $\alpha$ -particles and one  $\beta^-$  particle are emitted.
- As a result, a nucleus of actinium, Ac, is formed.

What is the correct notation for the nuclide of actinium that is formed?

- A  ${}_{87}^{227}\text{Ac}$       B  ${}_{89}^{227}\text{Ac}$       C  ${}_{87}^{231}\text{Ac}$       D  ${}_{89}^{231}\text{Ac}$

40 Which particle is a fundamental particle?

- A electron
- B hadron
- C neutron
- D proton

---

Permission to reproduce items where third-party owned material protected by copyright is included has been sought and cleared where possible. Every reasonable effort has been made by the publisher (UCLES) to trace copyright holders, but if any items requiring clearance have unwittingly been included, the publisher will be pleased to make amends at the earliest possible opportunity.

To avoid the issue of disclosure of answer-related information to candidates, all copyright acknowledgements are reproduced online in the Cambridge Assessment International Education Copyright Acknowledgements Booklet. This is produced for each series of examinations and is freely available to download at [www.cambridgeinternational.org](http://www.cambridgeinternational.org) after the live examination series.

Cambridge Assessment International Education is part of the Cambridge Assessment Group. Cambridge Assessment is the brand name of the University of Cambridge Local Examinations Syndicate (UCLES), which itself is a department of the University of Cambridge.